



# General Pricelist December 2009

( Update 12 July 2010 )

## Table of Contents:

Terms and Conditions, Warranty Information .....	16
Vaporizers	
Water Bath Vaporizers .....	3
Options and Accessories for Water Bath Vaporizers .....	2
Heat Transfer Solution .....	2
Vertical Water Bath Vaporizers .....	4
Steam Vaporizers .....	5
LPG Vapor/Air Mixing Systems	
Options and Spare Parts for Venturi Type Mixing Systems .....	6
Venturi Type Mixing Systems .....	7
Options and Accessories for Piston Operated Mixing Systems .....	8
Piston Operated Mixing Systems .....	9
Vaporizer/Mixer Combinations	
Water Bath Vaporizers with Venturi Mixing Systems .....	11
Options and Spare Parts for Water Bath Vaporizers with Venturi Mixing Systems .....	10
Water Bath Vaporizers with Piston Operated Mixing Systems .....	13
Options and Spare Parts for Water Bath Vaporizers with POM Mixing Systems .....	12
Accessories	
Flare Burner Heads .....	14
Coalescing Filters (LPG Vapor Filters) .....	14
Truck Unload Stations .....	14
Liquid Transfer Pump Packages .....	15
Starter Packages for Liquid Transfer Pumps .....	15

This price list is a minor update to the price list of December 2009 and supersedes it and all previous price lists. Prices and other information shown in this list are believed to be accurate at the time of printing. They are given for standard equipment, standard options, and standard product configurations. All sales are subject to the terms and conditions as shown on page 16 of this price list. Please contact the factory or your nearest authorized AES distributor for a price quote and current delivery times. **Prices and product configurations are subject to change at any time and without notice.**

## Options and Accessories for Horizontal Water Bath Vaporizers

Listed below are the most common options and accessories for Horizontal Water Bath Vaporizers. Additional factory-installed options and accessories are available to meet almost any needs a customer may have. This includes non-standard control systems (higher-level Allen-Bradley PLCs such as CompactLogix, ControlLogix, and SLC; Siemens S7-300 PLCs); non-standard paint colors; Utility Packages with dual temperature controllers and high-capacity water circulation pumps; etc.

Please contact your area distributor or the factory to discuss your specific needs.

Standard Options Standard Accessories	WB - 168	WB - 208	WB - 258	WB - 308	WB - 358	WB - 408	WB - 458	WB - 508	WB - 455	WB - 555	WB - 655	WB - 755	WB - 855	WB - 1005	WB - 1205	WB - 1505	WB - 1805	WB - 2005	WB - 2205	WB - 2505	WB - 3005	WB - 3505	WB - 4505	WB - 5505	WB - 7005	WB - 10005	WB - 12005	WB - 15005
	ASME "U"-Stamp or PED for CE Mark	\$ 1,861.00				\$ 2,797.00				\$ 3,290.00				\$ 5,184.00				contact AES										
Extended Control Room	N/A				\$ 3,681.00				\$ 0.00 (Standard)																			
Enclosure Fan with Thermostat	\$ 621.00																											
UL508a Stamp or CE for Control Panel	\$ 1,600.00												\$ 2,600.00												contact AES			
<b>PLC Configurations</b>																												
S7-1200 / HMI5070	Siemens S7-1200 with Ethernet Interface and 7-inch high-resolution (800x480) Touch Screen \$ 0.00 (Standard Configuration)																											
ML-1100 / HMI504T	Allen-Bradley MicroLogix-1100 with Ethernet Interface and 4.3-inch high-resolution (480x272) Touch Screen \$ 0.00 (available at no additional charge)																											
S7-1200 / HMI277-6 Web	Siemens S7-1200 with 6-inch (320x240) Siemens Touch Panel with built-in Web Server for Remote Access and Control \$ 2,792.00																											
S7-1200 / HMI277-8 Web	Siemens S7-1200 with 8-inch (640x480) Siemens Touch Panel with built-in Web Server for Remote Access and Control \$ 3,634.00																											
S7-200 / HMI5070	Siemens S7-200 with Ethernet Interface or Profibus DP Interface and 7-inch high-resolution EOI (800x480) \$ 1,277.00																											
ML-1100 / HMI5070	Allen-Bradley MicroLogix-1100 with Ethernet Interface and 7-inch high-resolution (800x480) Touch Screen \$ 1,277.00																											
ML-1100 / PVP-6	Allen-Bradley MicroLogix-1100 with Ethernet Interface and 6-inch Allen-Bradley PanelView-Plus (320x240) \$ 3,085.00																											
ML-1100 / PVP-7	Allen-Bradley MicroLogix-1100 with Ethernet Interface and 7-inch Allen-Bradley PanelView-Plus (640x480) \$ 5,510.00																											
Allen-Bradley Factory Talk View ME ST	Software with single license for remote access to systems with Allen-Bradley PLC \$ 3,575.00																											
Other PLC/EOI Configurations	Other PLC/EOI Configurations, for example Siemens S7-300, Allen-Bradley CompactLogix, Bristol ControlWave Micro, GE 90-30, and others are available. Contact AES with your specific needs.																											
Other Vaporizer Options	Other vaporizer options, for example high-pressure, installation in ISO shipping containers, air conditioning for Control Room, wireless Ethernet bridge, Utility Package, etc., are available. Contact AES with your specific needs.																											

## JEFFCOOL®-P155 Heat Transfer Solution

Water Bath Vaporizers use - as the name implies - water as the heat transfer medium. However, since the heat exchanger components and the bath box of the WB series are manufactured from carbon steel, it is recommended that the heat transfer solution be a mixture of water and an industrial coolant/heat transfer fluid with inhibitors to provide rust/corrosion protection.

Under no circumstances should an automotive grade coolant be used as the heat transfer fluid. Using standard automotive coolant could cause premature deterioration of the heat exchangers.

It is also recommended that the water in the heat transfer solutions be de-ionized. While it is acceptable to use very small amounts of standard tapwater to replenish any water that might have evaporated, it is not recommended to use standard tap-water for the initial charge of the water bath. If at all possible, topping-off should be done with pre-diluted solutions at the required system concentration.

Alternate Energy Systems recommends a 50/50 Propylene-Glycol/DI-Water solution for all installations. This mixture will provide burst protection to -60°F (-50°C), and will provide freeze protection to -30°F (-34°C), while providing a maximum of corrosion protection.

Alternate Energy Systems has selected JEFFCOOL® P150 heat transfer fluid (manufactured by Huntsman Corporation, The Woodlands, TX) as our preferred heat transfer solution. We are stocking JEFFCOOL® P150 heat transfer fluid, pre-mixed 50/50 (= P155) with DI-Water, in 55-gallon drums and in 275-gallon totes, and can ship the quantities needed for the initial charge on the same truck as the vaporizer at no, or very minimal, additional shipping charges. If required, we can also provide a small utility pump, complete with suction hose and discharge hose, for the transfer of the JEFFCOOL® P150 heat transfer fluid from the drums or totes to the vaporizer.

AES Part #	Description	Price in US-\$
HTS0055	Jeffcool P155 transfer solution in 55-gallon non-returnable plastic drum (see Note 2)	\$ 738.00 / drum
HTS0275	Jeffcool P155 heat transfer solution in 275-gallon non-returnable plastic tote with steel-cage reinforcement (see Note 2)	\$ 3,690.00 / tote
HTS0004	Maintenance Sample Kit, including self-addressed shipping box, pre-labeled sample bottle, weather-proof self-adhesive product installation tag and detailed sampling procedures. Analytical results from the samples will be forwarded by the laboratory directly to our customer.	See Note 1
HTS0005	Utility Pump Kit for the transfer of Jeffcool P155 from the shipping containers to the vaporizer. Kit includes industrial-grade pump for AC110V 60Hz Single Phase (transfer rate approximately 365 gallons per hour): 10-ft. suction hose; 40-ft. discharge hose.	\$ 423.00

Note 1: Available at no charge to customers who have purchased their Heat Transfer Solution through AES. Contact AES for pricing if your Heat Transfer Solution is not JEFFCOOL®-P155, or if it was not purchased from AES.

Note 2: JEFFCOOL®-P155 is delivered in non-returnable containers. The cost of the containers is included in the price of the Heat Transfer Solution. AES accepts returned containers (freight pre-paid) for recycling and will credit the customer's account \$35.00 for each returned 55-gallon drum, and \$70.00 for each returned 275-gallon tote.

## Horizontal Water Bath Vaporizers

AES manufactures two lines of Water Bath Vaporizers, the 08-Series for capacities from 168 gph to 508 gph (322 kg/h to 975 kg/h), and the 05-Series for capacities from 455 gph to 10005 gph (873 kg/h to 20 metric tons per hour).

All AES water bath vaporizers are of "horizontal" design. Top, sides, and rear are insulated to hold the temperature of the water bath. The vaporizing tube bundle and all LPG piping conform to the standards of the ASME Boiler and Pressure Vessel Code and the latest edition of NFPA Pamphlet #58. The design is approved by Factory Mutual (FM) and Canadian Standards Association (CSA), and is accepted for Industrial Risk Insurers (IRI) installations. The vaporizers are also available with European CE Approval (third-party inspection by TÜV Rheinland).



A mixture of water and antifreeze is the heat transfer medium. A pump constantly circulates the solution to reduce heat stratification. The vaporizers are skid mounted, factory tested, primed, painted and ready for installation. They are ready for connection to properly sized electrical supply, liquid propane inlet and vapor outlet.

The vaporizers come with 2 sets of Operating Manuals and Test Reports, are designed for outdoor installation, and require only nominal preventive maintenance.

The model number (WB-xxxx) designates the vaporization capacity in gallons per hour Propane vaporization at 0°F (-18°C) inlet temperature.

All WB vaporizers are manufactured with a protective enclosure for the burner and the control components. Models WB-1805 and above are equipped with an extended control room (maintenance house), which is available as an option for the smaller models WB-455 to WB-1505.

Model numbers ending in "8" utilize a European-style compact power burner; model numbers ending in "5" utilize Maxon TOT burners (or similar types). Both series are equipped with Agency-approved Safety Relays and electronic flame safe guard. This combination elevates the safety of the vaporizers to "Performance Level 3" (formerly known as SIL 4).

Both series of vaporizers are equipped with "Smart" Liquid Carryover Protection function, using a Rosemount pressure transmitters and a Rosemount temperature transmitter in the vapor outlet.

Prices for all models include a control panel with Siemens S7-1200 or Allen-Bradley MicroLogix-1100 PLC and a high-resolution color LCD display with Touch Screen Operator Interface for system status display and first-outage indication. Ethernet Interface is standard on all PLCs. The Siemens PLCs are also available with Profibus DP interface; and with remote monitoring and control via a web browser, without the need for additional software.

Detailed equipment description can be found in AES brochure "Water Bath LPG Vaporizers".

Model Number	Nominal Capacity in gal per hour	Nominal Capacity in kg/h	Burner Input in MMBTU/h	Dimensions In inches			Water Tank Capacity In gallons	Shipping Weight in lbs.	Price in US-\$
				W	L	H			
WB-168	168	322	0.200	48	132	112	165	3500	\$24,000.00
WB-208	208	399	0.250	48	132	112	165	3500	\$26,000.00
WB-258	258	495	0.310	48	132	112	165	3500	\$30,000.00
WB-308	308	585	0.370	48	132	112	165	3500	\$33,000.00
WB-358	358	687	0.430	48	132	112	165	3500	\$35,000.00
WB-408	408	783	0.490	48	132	112	165	3500	\$36,500.00
WB-458	458	879	0.550	48	132	112	165	3500	\$38,000.00
WB-508	508	975	0.610	48	132	112	165	3500	\$41,000.00
WB-455	455	873	0.540	72	138	112	220	5400	\$44,430.00
WB-555	555	1065	0.660	72	138	112	220	5400	\$47,535.00
WB-655	655	1257	0.780	72	138	112	220	5400	\$51,324.00
WB-755	755	1449	0.900	72	142	112	385	6200	\$56,491.00
WB-855	855	1640	1.020	72	142	112	385	6200	\$59,585.00
WB-1005	1005	1928	1.200	78	164	112	495	8000	\$68,021.00
WB-1205	1205	2312	1.440	78	164	112	495	8000	\$73,642.00
WB-1505	1505	2888	1.800	78	164	112	495	8000	\$82,129.00
WB-1805	1805	3463	2.160	84	204	112	990	14000	\$93,005.00
WB-2005	2005	3847	2.400	84	204	112	990	14000	\$107,111.00
WB-2205	2205	4231	2.640	84	204	112	990	14000	\$110,687.00
WB-2505	2505	4807	3.000	84	204	112	990	14000	\$123,395.00
WB-3005	3005	5766	3.750	84	240	112	2035	16500	\$132,608.00
WB-3505	3505	6726	4.200	84	240	112	2035	16500	\$141,889.00
WB-4505	4505	8645	5.400	84	310	112	2420	20000	\$165,909.00
WB-5505	5505	10534	6.600	84	310	112	2420	20000	\$191,312.00
WB-7005	7005	13442	8.400	These Vaporizers are typically manufactured to meet customer-specific requirements. Please contact your area distributor or the factory to discuss your specific needs.					
WB-10005	10005	19199	12.000						

Weights and dimensions are approximate. Specifications are subject to change without notice. Call factory or distributor for price quotation and actual lead times.

## Vertical Circulating Water Bath Vaporizers

Alternate Energy Systems offers a complete line of circulating hot water vaporizers in capacities from 200 gallons per hour to 3000 gallons per hour. The steam tube is of multi-pass design to transfer the maximum heat to the liquid. The tube bundle and all propane piping conform to Section VIII, Division I of the latest edition of the ASME Boiler and Pressure Vessel Code. The pressure vessel carries the ASME "U" stamp and is National Board registered.

The prices shown below include dual liquid carryover protection through an ultrasonic liquid level transmitter in the pressure vessel, and "smart" liquid carryover protection with Rosemount pressure transmitter and temperature transmitter in the vapor outlet; and liquid inlet valve (solenoid valve). Temperature gauges in water inlet and outlet, and in pressure vessel shell and vapor outlet are standard.

Vaporizer design, wiring, controls, and electrical components and their installation comply with the latest editions of NFPA #58 and NFPA #70.

All safety devices of the vaporizer, including the dual liquid carryover protection, are monitored by a programmable logic controller (Allen-Bradley MicroLogix), which is connected to a color LCD display with Touch Screen Operator Interface. The operator interface provides start/stop control for the vaporizer; it displays the system status, and any failure conditions that may occur, in plain English (with date/time stamp). The electrical enclosure for the PLC and the operator interface are to be installed in a remote, non-classified location. A small explosion-proof enclosure, mounted to the vaporizer, provides local start/stop and alarm reset functions.

Standard lead time on all models is 6 weeks. Actual lead times depend on factory workload and may vary.

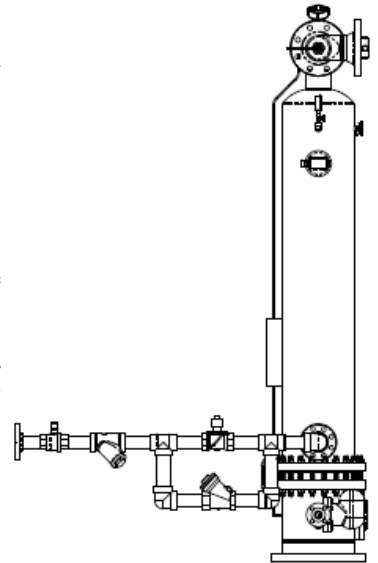

Model Number	Nominal Capacity (Propane up to 30/70 Propane/Butane)				Water Flow (185°F / 85°C)		Heat Exchanger Dimensions		Shipping Weight		Price in US-\$
	gph	MMBTU/h	kg/h	MMkcal/h	gpm	l/min	D x H [in]	D x H [mm]	lbs	kg	
VWB- 400	200	18.4	400	46	23	85	<b>Consult Factory</b>				\$ 25,946.00
VWB- 800	400	37	800	93	46	170					\$ 29,221.00
VWB-1200	600	55	1200	139	69	255					\$ 32,759.00
VWB-1600	800	74	1600	185	92	340					\$ 35,850.00
VWB-2000	1000	92	2000	232	115	425					\$ 39,963.00
VWB-3000	1500	138	3000	348	173	638					\$ 50,330.00
VWB-4000	2000	184	4000	464	230	850					\$ 56,719.00
VWB-5000	2500	230	5000	580	288	1063					\$ 60,165.00
VWB-6000	3000	276	6000	696	345	1275					\$ 70,064.00

Water Flow Requirements are based on 185°F (85°C) water temperature and 40°F (22°C) inlet/outlet temperature drop.  
Weights and dimensions are approximate. Dimensions are for heat exchanger shell only. Trim and accessories are not included in dimensions.  
Specifications are subject to change without notice. Call factory or distributor for price quotation and actual lead times.

Standard Options and Accessories	VWB-400	VWB-800 VWB-1200	VWB-1600 VWB-2000	VWB-3000 VWB-4000	VWB-5000 VWB-6000
Skid Mounting	36"x48" \$1,577.00	36"x48" \$1,577.00	48"x48" \$1,801.00	48"x48" \$1,801.00	48"x48" \$1,801.00
Enclosure (walk-in Maintenance House); includes skid mounting, personnel door, overhead lighting, alarm beacon, and control panel installation in enclosure.	36"x96"x100" \$14,861.00	36"x96"x100" \$14,861.00	48"x96"x100" \$16,469.00	48"x96"x100" \$16,469.00	48"x96"x100" \$16,469.00
Chinese Pressure Vessel Approval (SQL)	\$2,048.00	\$2,616.00	\$3,047.00	\$4,012.00	\$4,821.00
Ethernet Adapter for System Control Panel.	Standard on all VWB-models. Siemens S7-1200 PLC or Allen-Bradley MicroLogix-1100, both with integrated Ethernet Interface and high-resolution (800x480) color LCD display with touch screen operator interface.				
Remote Access, Siemens	Siemens S7-1200 with 6-inch (320x240) Siemens Touch Panel with built-in Web Server for Monitoring and Control through standard web browser; no special software required. \$ 2,792.00				
Remote Access, Allen-Bradley	Factory Talk View ME Station; Software with single license for remote access to systems with Allen-Bradley PLC. \$ 3,575.00				
<b>Deduct</b> for Standard Controls	-\$5,124.00 no PLC or Operator Interface; no "smart" Liquid Carryover Protection; standard Start/Stop Station only.				

## Vertical Steam Vaporizers

Alternate Energy Systems offers a complete line of vertical steam vaporizers in capacities from 200 gallons per hour to 3000 gallons per hour. The steam tube is of multi-pass design to transfer the maximum heat to the liquid. The tube bundle and all propane piping conform to Section VIII, Division I of the latest edition of the ASME Boiler and Pressure Vessel Code. The pressure vessel carries the ASME "U" stamp and is National Board registered.

The prices shown below include steam temperature regulator; dual liquid carryover protection through ultrasonic liquid level transmitter in the pressure vessel, and "smart" liquid carryover protection with Rosemount pressure transmitter and temperature transmitter in the vapor outlet; liquid inlet valve (solenoid valve); steam trap; and steam back check valve. Temperature gauges in steam inlet and outlet, and in pressure vessel shell and vapor outlet are standard.

Vaporizer design, wiring, controls, and electrical components and their installation comply with the latest editions of NFPA #58 and NFPA #70.

All safety devices of the vaporizer, including the dual liquid carryover protection, are monitored by a programmable logic controller (Allen-Bradley MicroLogix), which is connected to a color LCD display with Touch Screen Operator Interface. The operator interface provides start/stop control for the vaporizer; it displays the system status, and any failure conditions that may occur, in plain English (with date/time stamp). The electrical enclosure for the PLC and the operator interface are to be installed in a remote, non-classified location. A small explosion-proof enclosure, mounted to the vaporizer, provides local start/stop and alarm reset functions.

Standard lead time on all models is 6 weeks. Actual lead times depend on factory workload and may vary.

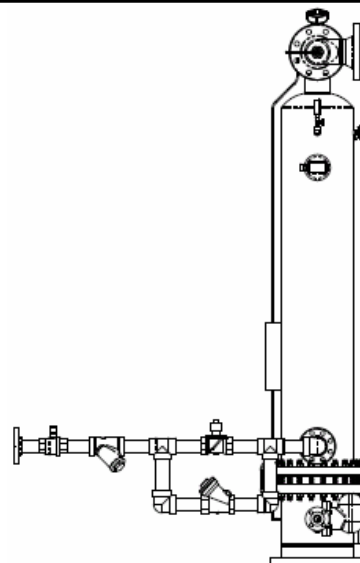

Model Number	Nominal Capacity (Propane up to 30/70 Propane/Butane)				Steam Consumption (max 400°F / 204°C)		Heat Exchanger Dimensions		Shipping Weight		Price in US-\$
	gph	MMBTU/h	kg/h	MMkcal/h	lbs/hr	kg/hr	D x H [in]	D x H [mm]	lbs	kg	
VSV- 200	200	18.4	400	46	200	91					\$ 28,938.00
VSV- 400	400	37	800	93	400	182					\$ 32,212.00
VSV- 600	600	55	1200	139	600	272					\$ 36,496.00
VSV- 800	800	74	1600	185	800	363					\$ 39,587.00
VSV-1000	1000	92	2000	232	1000	454					\$ 45,570.00
VSV-1500	1500	138	3000	348	1500	681					\$ 55,938.00
VSV-2000	2000	184	4000	464	2000	908					\$ 64,197.00
VSV-2500	2500	230	5000	580	2500	1135					\$ 67,641.00
VSV-3000	3000	276	6000	696	3000	1362					\$ 77,541.00

Consult  
Factory

Steam Consumption is directly proportional to momentary load (example: if vaporizer is used at 50% nominal capacity, it consumes only 50% of max. steam consumption).  
Weights and dimensions are approximate. Dimensions are for heat exchanger shell only. Trim and accessories are not included in dimensions.  
Specifications are subject to change without notice. Call factory or distributor for price quotation and actual lead times.

Standard Options and Accessories	VSV-200	VSV-400 VSV-600	VSV-800 VSV-1000	VSV-1500 VSV-2000	VSV-2500 VSV-3000
Skid Mounting	36"x48" \$1,577.00	36"x48" \$1,577.00	48"x48" \$1,801.00	48"x48" \$1,801.00	48"x48" \$1,801.00
Enclosure (walk-in Maintenance House); includes skid mounting, personnel door, overhead lighting, alarm beacon, and control panel installation in enclosure.	36"x96"x100" \$14,861.00	36"x96"x100" \$14,861.00	48"x96"x100" \$16,469.00	48"x96"x100" \$16,469.00	48"x96"x100" \$16,469.00
Chinese Pressure Vessel Approval (SQL)	\$2,048.00	\$2,616.00	\$3,047.00	\$4,012.00	\$4,821.00
Ethernet Adapter for System Control Panel.	Standard on all VVB-models. Siemens S7-1200 PLC or Allen-Bradley MicroLogix-1100, both with integrated Ethernet Interface and high-resolution (800x480) color LCD display with touch screen operator interface.				
Remote Access, Siemens	Siemens S7-1200 with 6-inch (320x240) Siemens Touch Panel with built-in Web Server for Monitoring and Control through standard web browser; no special software required. \$ 2,792.00				
Remote Access, Allen-Bradley	Factory Talk View ME Station; Software with single license for remote access to systems with Allen-Bradley PLC. \$ 3,575.00				
<b>Deduct</b> for Standard Controls	-\$5,124.00 no PLC or Operator Interface; no "smart" Liquid Carryover Protection; standard Start/Stop Station only.				

## Options, Accessories and Spare Parts for HVS Mixers

The following list shows the most commonly requested options, accessories and spare parts for HVS series LPG/Air mixers. Unless listed otherwise, all parts fit all models and all model-years after 1985, except for models modified for specific applications. When ordering spare parts, please provide the serial number of your HVS Mixer.

Part Number	Description	Price in US-\$
HVSOPT-1	For Models HVS-7MM to HVS-20MM only: Electronic controls with Siemens S7-1200 or Allen-Bradley MicroLogix-1100 PLC; includes Rosemount pressure transmitters and high-resolution (800 x 480) color LCD display with touch-screen operator interface. Includes Venturi Cycle Counter. Ethernet interface included.	\$ 7,761.00
HVSOPT-S7W	Siemens S7-1200 with 6-inch (320x240) Siemens Touch Panel with built-in Web Server for Remote Access and Control (Systems with PLC only)	\$ 2,792.00
SWI0030	Pressure switch, Low LPG; for systems with electro-mechanical controls;	\$ 597.70
SWI0033	Pressure switch, Tank Monitor, 2 setpoints; for systems with electro-mechanical controls;	\$ 788.60
SWI0029	Pressure switch, Tank Monitor, 3 setpoints; for systems with electro-mechanical controls;	\$ 989.50
TRA0056	Tank Monitor Pressure Transmitter; 0-30 psi, 4-20 mA; for systems with PLC controls;	\$ 1,918.00
TRA0058	Vapor Pressure Transmitter; 0-300 psi, 4-20 mA; for systems with PLC controls;	\$ 1,918.00
VAL0012M	Instrument valve (in pressure gauge line);	\$ 17.50
GAU0005	Pressure gauge; liquid filled; stainless steel case, brass internals; with case vent; 15 psi;	\$ 39.50
GAU0001	Pressure gauge; liquid filled; stainless steel case, brass internals; with case vent; 30 psi;	\$ 39.50
GAU0002	Pressure gauge; liquid filled; stainless steel case, brass internals; with case vent; 100 psi;	\$ 39.50
GAU0006	Pressure gauge; liquid filled; stainless steel case, brass internals; with case vent; 300 psi;	\$ 39.50
SOL0073	Solenoid valve, non-explosion-proof; for venturi assembly; valve can be used in "static" or "dynamic" positions in venturi line;	\$ 308.80
SOL0073R	Repair kit for solenoid non-explosion-proof solenoid valve; (includes Solenoid Coil; specify voltage DC24V or AC110V 60Hz or AC220V 50Hz);	\$ 200.60
SOL0073C	Solenoid Coil, non-explosion-proof (specify voltage DC24V or AC110V 60Hz or AC220V 50Hz);	\$ 91.10
SOL0082	Solenoid valve, explosion-proof; for venturi assembly; valve can be used in "static" or "dynamic" positions in venturi line;	\$ 448.60
SOL0082R	Repair kit for solenoid explosion-proof solenoid valve; (includes Solenoid Coil; specify voltage DC24V or AC110V 60Hz or AC220V 50Hz);	\$ 291.40
SOL0082C	Solenoid Coil, explosion-proof; (specify voltage DC24V or AC110V 60Hz or AC220V 50Hz);	\$ 132.30
VAL0002	Valve Assembly, Air Intake, complete; includes valve body, back plate, check plate, bronze bearing sleeve, gasket, Venturi Nozzle (specify "C" for 7MM or "D" for 10MM with order), O-rings, self-locking nut, stainless steel spring, spring retainer;	\$ 1,660.20
VAL0084	Check valve: backplate for air intake;	\$ 247.00
VAL0085	Check valve: check-plate for air intake;	\$ 258.10
GAS0014	Check valve: gasket for air intake;	\$ 15.00
SPR0001	Check valve: spring, stainless steel	\$ 62.00
NOZ0003	Venturi Nozzle, Type "C";	\$ 691.80
NOZ0004	Venturi Nozzle, Type "D";	\$ 691.80
VEN0001	Venturi Tube, Type "M";	\$ 1,221.70
VEN0002	Venturi Tube, Type "N";	\$ 1,221.70
NOZ0007	Venturi Nozzle, Type "E";	\$ 816.30
NOZ0008	Venturi Nozzle, Type "F";	\$ 816.30
VEN0009	Venturi Tube, Type "O";	\$ 1,346.20
VEN0010	Venturi Tube, Type "P";	\$ 1,346.20
REG0006	Regulator in vapor supply line to Venturi Mixer;	\$ 548.40
REG0006R	Repair Kit for regulator in vapor supply line to Venturi Mixer;	\$ 188.60

## HVS LPG-Vapor / Air Mixers

All HVS Systems are designed to be used with an existing LPG vapor source, such as a vaporizer, or as the replacement for less efficient or less reliable LPG-vapor/air mixing systems. They come complete with steel skid, vapor inlet header, venturi arrangements, surge tank, electric/electronic controls, and all other equipment necessary for safe operation. The produced gas is directly compatible, and interchangeable, with NatGas.

All HVS systems monitor the gas pressure in the surge tank. Smaller systems up to two venturi arrangements use pressure switches and standard controls. Larger systems with three or more venturi arrangements use a pressure transmitter which is connected to a Siemens or Allen-Bradley PLC. The PLC "sequences" the venturi lines and controls all system safety functions. The PLC also communicates with a color LCD display with Touch Screen Operator Interface, indicating system pressures, and any trouble conditions that may occur. The PLC may also be used to "interlock" the HVS system with an external vaporizer.

Installations where the mixer system is separated from an open-flame vaporizer, and installations with electric vaporizers, require the option "Explosion Proof Control Components", which includes explosion proof transmitters and solenoid valves. The control panel for these mixers must be installed in a non-hazardous location. A local start/stop station in an explosion-proof enclosure provides basic control over the mixer. The main control panel for these mixers, with PLC and operator interface, must be installed in a non-hazardous location.

All HVS Mixers are equipped with two solenoid valves per venturi train. The "dynamic" solenoid valve opens and closes each time a venturi train is activated to produce mixed gas. The "static" solenoid valves opens when the mixer is started and stays open until the mixer is stopped, or until a high-pressure alarm occurs. This feature provides an additional level of safety and prevents the unwanted discharge of mixed gas in case of a failure of the "dynamic" solenoid valve.

HVS mixers with electronic controls (PLC) allow the adjustment of the sendout pressure and the sequencing of the venturi lines (differential pressure between trains; ON-OFF deadband) through simple inputs at the operator interface. These versions also offer a "Venturi Cycle Counter" for each venturi train. The counter increments each time a venturi train is activated. This information can be used to determine when the mechanical components of a venturi train should be closely inspected, overhauled, or replaced.

The required vapor supply pressure depends on the desired sendout pressure, on the type of available LPG (Propane/Butane content), and on other factors (i.e. altitude). Typical supply pressures for "Propane" and 5-8 psi sendout pressure are 50-70 psi. Systems with higher sendout pressure of 9-12 psi require considerably higher vapor supply pressure, which can be difficult to maintain in very cold climates. Mixed Gas Sendout Pressures of more than 12 psi require the High Pressure option, which includes an ASME "U"-stamped surge tank.

Please Note: Venturi-based LP/Air mixers are generally considered "for intermittent use". Due to the relatively limited useful life of their dynamically exercised mechanical components (regulators, check valves, solenoid valves, air intake valves, etc. are typically specified to withstand 200000 to 500000 cycles), they are not very well suited for baseload applications. Their main application is "Emergency Backup".

Compact HVS: Models with one or two venturi trains (HVS-7, HVS-10, HVS-14, HVS-20) are also available in "Compact" configuration. These models are specifically designed for air freight shipment (small footprint, reduced height, removable relief valve stack, etc.). There is no price adder for these models.

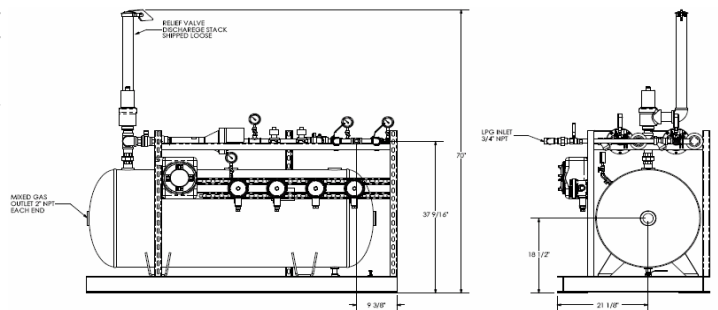

Model Number	Nominal MMBTU/h (9 to 12 psi)	Number of Venturis (9 to 12 psi)	Surge Tank Capacity US-gal (liter)	Approximate Skid Size in Inches (mm)	Price in US-\$ 5 to 8 psi	Price in US-\$ 9 to 12 psi	Price in US-\$ High Pressure	Price in US-\$ Ex-Proof
HVS - 7	7 (N/A)	1(N/A)	120 (450)	54 x 54 x 83	\$15,519.00	N/A	\$3,122.00	\$2,993.00
HVS - 10	10 (10)	1 (1)	120 (450)	54 x 54 x 83	\$15,519.00	\$16,448.00	\$3,122.00	\$2,993.00
HVS - 14	14 (N/A)	2(N/A)	120 (450)	54 x 54 x 83	\$18,821.00	N/A	\$4,813.00	\$3,561.00
HVS - 20	20 (21)	2 (2)	120 (450)	54 x 54 x 83	\$25,039.00	\$26,665.00	\$4,813.00	\$3,561.00
HVS - 30	30 (28)	3 (3)	250 (950)	65 x 102 x 70	\$33,064.00	\$35,127.00	\$6,724.00	\$6,589.00
HVS - 40	40 (42)	4 (4)	250 (950)	65 x 102 x 70	\$38,713.00	\$41,593.00	\$8,413.00	\$7,156.00
HVS - 50	50 (49)	5 (4)	250 (950)	65 x 102 x 70	\$44,364.00	\$47,162.00	\$9,908.00	\$7,724.00
HVS - 60	60 (63)	6 (5)	500 (1893)	65 x 128 x 80	\$52,978.00	\$56,728.00	\$11,599.00	\$6,433.00
HVS - 70	70 (70)	7 (6)	500 (1893)	65 x 128 x 80	\$58,627.00	\$63,254.00	\$13,289.00	\$7,001.00
HVS - 80	80 (77)	8 (6)	500 (1893)	65 x 128 x 80	\$64,276.00	\$68,780.00	\$14,787.00	\$7,571.00
HVS - 90	90 (91)	9 (7)	1000 (3785)	65 x 199 x 84	\$72,551.00	\$77,929.00	\$16,695.00	\$8,138.00
HVS - 100	100 (105)	10 (8)	1000 (3785)	65 x 199 x 84	\$78,201.00	\$84,478.00	\$18,386.00	\$8,706.00
HVS - 110	110 (112)	11 (9)	1000 (3785)	65 x 199 x 84	\$83,850.00	\$91,038.00	\$20,077.00	\$9,274.00
HVS - 120	120 (119)	12 (9)	1000 (3785)	call factory	\$89,500.00	\$95,616.00	\$22,745.00	\$9,842.00
HVS - 130	130 (133)	13 (10)	1000 (3785)	call factory	\$95,205.00	\$102,107.00	\$24,435.00	\$10,410.00
HVS - 140	140 (140)	14 (11)	1000 (3785)	call factory	\$100,797.00	\$108,611.00	\$26,126.00	\$10,980.00
HVS - 150	150 (154)	15 (12)	1000 (3785)	call factory	\$106,412.00	\$115,126.00	\$27,816.00	\$11,546.00
HVS - 160	160 (161)	16 (12)	1000 (3785)	call factory	\$112,097.00	\$120,684.00	\$29,311.00	\$12,115.00
HVS - 170	170 (168)	17 (13)	1000 (3785)	call factory	\$117,747.00	\$127,208.00	\$31,002.00	\$12,683.00
HVS - 180	180 (182)	18 (14)	1000 (3785)	call factory	\$128,232.00	\$138,979.00	\$32,693.00	\$13,250.00
HVS - 190	190 (189)	19 (14)	1000 (3785)	call factory	\$133,908.00	\$144,503.00	\$34,189.00	\$13,818.00
HVS - 200	200 (203)	20 (15)	1000 (3785)	call factory	\$139,531.00	\$151,054.00	\$35,877.00	\$14,389.00
HVS - 210	210 (210)	21 (16)	1000 (3785)	call factory	\$145,182.00	\$156,262.00	\$38,742.00	\$14,956.00
HVS - 220	220 (224)	22 (17)	1000 (3785)	call factory	\$155,667.00	\$167,989.00	\$40,431.00	\$15,523.00
HVS - 230	230 (231)	23 (17)	1000 (3785)	call factory	\$161,317.00	\$173,539.00	\$41,927.00	\$16,091.00
HVS - 240	240 (238)	24 (18)	1000 (3785)	call factory	\$166,966.00	\$180,064.00	\$43,617.00	\$16,659.00
HVS - 250	250 (252)	25 (19)	1000 (3785)	call factory	\$177,448.00	\$191,820.00	\$45,309.00	\$17,230.00

## Options and Accessories for POM Blenders

The following is an abbreviated list of available options and accessories for POM Blenders. Many more options and non-standard configurations are available to meet the requirements of (almost) any application. Unless stated otherwise, all options are available for all POM models.

If you need a blender that cannot be configured using the options listed below, please contact your area distributor or the factory.

Part Number	Description	Price in US-\$
GB-3	Option: GraviBlend™-3, Gravimeter for LPG/Air mixtures, Standard Configuration for non-classified areas, Range 0.2 ... 2.2 (relative density). High-speed, high-accuracy, on-line gravimeter; measures and indicates specific gravity of mixed gas.  Powder coated steel NEMA 4 wall-mount enclosure; integrated filter element in sample gas line; integrated consumption jet in sample gas line; integrated sample gas bypass with precision instrument valve; full-graphic color LCD display with touch screen operator interface (see Note 1); direct display of Specific Gravity, Calorific Value, and Wobbe Index number; electronic signal processor (see Note 1) with alarm contacts; internally powered analog output signal 4...20 mA (source; scaled to 0.4 ... 2.0 SG) for external recording instruments; AC110V 60Hz or AC220V 50Hz; graphic trend recording function; semi-automatic calibration feature.	\$16,934.00
GB-3E	Option: GraviBlend™-3E, Gravimeter for LPG/Air mixtures, Explosion-Proof Configuration for classified areas, Range 0.2 ... 2.2 (relative density). High-speed, high-accuracy, on-line gravimeter; measures and indicates specific gravity of mixed gas. Separate enclosures for electronic components, gas distribution elements, and density sensor.  Electronics Enclosure (see Note 1): powder coated steel NEMA 4 wall-mount enclosure; full-graphic color LCD display with touch screen operator interface; direct display of Specific Gravity, Calorific Value, and Wobbe Index number; electronic signal processor (see Note 1) with alarm contacts; internally powered analog output signal 4...20 mA (source; scaled to 0.4 ... 2.0 SG) for external recording instruments; AC110V 60Hz or AC220V 50Hz; graphic trend recording function; semi-automatic calibration feature.  Gas Distribution Enclosure: powder coated steel NEMA 4 wall-mount enclosure; integrated filter element in sample gas line; integrated consumption jet in sample gas line; integrated sample gas bypass with precision instrument valve; 1/8" bulkhead fittings for connection to Sensor Enclosure.  Sensor Enclosure: explosion-proof aluminum junction box with density sensor and signal conditioner, wall-mount (horizontally).	\$21,914.00
POMOPTACC	Option: AccuBlend™ System, Automatic Gas Properties Control. Electric actuator to adjust the angular position of the piston in the POM, and thereby correcting the calorific value of the mixed gas. Actuator is installed on top of the POM valve. Price includes proportional controller (integrated in electronic signal processor of GraviBlend™-3/3E; see Note 1), which receives a linear analog signal (4-20 mA or 0-5V) from the Gravimeter and sends a control signal to the actuator (requires "Option: Gravimeter").	\$8,855.00
POMOPTETH	Siemens S7-1200 with 6-inch (320x240) Siemens Touch Panel with built-in Web Server for Remote Access and Control. System can be accessed with a standard web browser. No special software required.	\$2,792.00
POMOPTFLOW	Flow Transmitter in sendout line; real-time SNG flow display on EOI. If the POM is equipped with a Gravimeter, LPG vapor flow, compressed air flow, and liquid LPG flow are also displayed. Dual Flow Totalizer (with individual reset) is standard for all displayed flow values.	\$7,909.00
POMOPTTEM	Option: Three Temperature Transmitters; installed in vapor supply, air supply line, and mixed gas line. Each transmits a 4-20 mA signal to the PLC in the system control panel. Temperature display in engineering units, i.e. °F or °C. Includes Hi/Lo alarm setpoints for each transmitter; includes expansion analog input module for PLC.	\$3,862.00
POMOPTMOD	Option: Module Unit. Installation of POM on same skid with water bath vaporizer. POM orientation is "vertical".	\$4,903.00
POMOPTX1	Option: Ex-proof control components; required for installations where the POM is more than 15 ft. away from a gas-fired vaporizer (U.S. rules), or where required by local law. Includes explosion-proof pressure transmitters in vapor supply line, air supply line, and mixed gas line. Includes explosion-proof control panel enclosure, mounted directly at the blender skid.	\$10,853.00
POMOPTX2	Option: Ex-proof control components; required for installations where the POM is more than 15 ft. away from a gas-fired vaporizer (U.S. rules), or where required by local law. Includes explosion-proof pressure transmitters in vapor supply line, air supply line, and mixed gas line. Includes powder coated NEMA 4 wall-mount enclosure for system control panel, to be installed in non-classified area. Interconnecting cable between explosion proof junction box at the blender skid and control panel is to be supplied and installed at job site. Maximum distance between blender and control panel approximately 2000 ft. (600 m). Includes local Start/Stop station, installed on blender skid.	\$6,076.00
POMOPTCE	Option: CE Approval; available for all POM models; compliant with PED, ATEX, and all other applicable European Directives.	\$6,882.00
POMPCKSHV	Option: Electronic PeakShaving Controller. Includes PLC upgrades (10- or 12-inch color LCD display with Touch Screen Operator Interface; Analog Output for Flow Control Valve). Includes user-selectable PeakShaving modes (i.e. "Inject fixed SNG Volume"; "Limit NG Flow"; "Maintain NG/SNG Ratio"; ...). Includes electronically controlled Flow Control Valve in Mixed Gas Sendout Line (pneumatically actuated); Flow Transmitter in Mixed Gas Sendout Line; Analog Inputs for Grid Flow (or NatGas Flow), and Grid Pressure; block valve in Mixed Gas Sendout Line (pneumatically actuated).	Call Factory

Note 1: If the GraviBlend™-3/3E gravimeter is ordered together with a POM blender, the electronic signal processor of the gravimeter will be integrated into the PLC of the POM. The electronic operator interface will be a 7-inch high-resolution color LCD display with touch screen operator interface. An upgrade to a 10-inch Siemens MP277 or Allen-Bradley PanelView-Plus is available at a nominal charge of US-\$2,800.00.

## POM LPG-Vapor/Air and NatGas/Air Blenders

All POM Systems are designed to be used with an existing LPG vapor source, such as a vaporizer, or as the replacement for less efficient or less reliable LPG-vapor/air mixing systems. They can also be used as NatGas/Air or NatGas/Nitrogen blenders (i.e. for NatGas stabilization) and come assembled on a steel skid, complete with electric/electronic controls, and all other equipment necessary for safe operation.

A PLC (Siemens S7-1200 or Allen-Bradley MicroLogix-1100) is used to monitor and control all system functions. The PLC also communicates with an Electronic Operator Interface (EOI) with color LCD display and touch screen, displaying all system pressures in real time. And any trouble conditions that may occur are displayed in plain English, and are recorded in the Alarm History. Graphic trend recording is standard.

The PLC may also be used to "interlock" the POM system with an external vaporizer. The standard mixer control panel is designed to be installed in a non-hazardous location. Ethernet Interface is standard.

Vapor inlet, air inlet, strainers, check valves, and regulators are "flanged". Pneumatically operated ball valves in vapor inlet and compressed air inlet are standard. The inlet valves are "fail-safe-closed" and will close automatically in the event of a power failure, or when a high-pressure condition exists.

Installations where the mixer system is separated from the water bath vaporizer (or other gas-fired vaporizer); installations with electric vaporizers; and some local codes; require the option "Explosion Proof Control Components", which also includes explosion proof transmitters and solenoid valves.

To find the right POM for your application, select the required nominal system capacity from the first column of the chart. Move to the right until you are below the system design pressure (delivered mixed gas pressure). The top row of the cell indicates the POM model number. The bottom row of the cell indicates the price for this configuration.

Nominal Capacity in BTU per hour (top row) and NatGas Equivalent\*\* (m<sup>3</sup>/h; bottom row) is approximate and is given for Propane/Air mixtures with 1450 BTU/cuft at delivered mixed gas pressures of 10 psig to 100 psig. Capacity for other LPG/Air mixtures and/or pressures may vary. Nominal Capacity is based on vapor and compressed air inlet pressures of 100-125 psig, and a pressure drop of 10% across the mixing valve at maximum flow. The minimum vapor and air supply pressures are "Sendout Pressure + 15 psi (1bar)".

Other Blender configurations (for lower or higher delivery pressures, higher flow rates, other blending gasses, different materials, ...) are available. Please contact the factory or your area distributor for details.

\*\* NatGas Equivalent: In most cases, POM blenders will be used to provide backup for a NatGas supply. Use the maximum expected NatGas flow per hour to select the correct POM model.

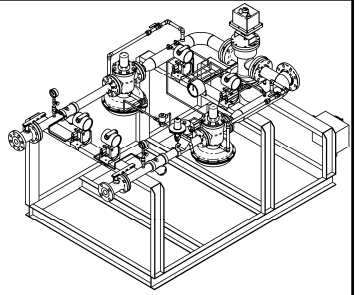

	10 psi 0.7 bar	20 psi 1.4 bar	30 psi 2.1 bar	40 psi 2.8 bar	50 psi 3.5 bar	60 psi 4.2 bar	70 psi 4.9 bar	80 psi 5.6 bar	90 psi 6.3 bar	100 psi 7 bar
20 MMBTU/h 560 m <sup>3</sup> /h	POM-30 \$66,920.00	POM-30 \$66,920.00	POM-30 \$66,920.00	POM-30 \$66,920.00	POM-30 \$66,920.00	POM-30 \$66,920.00	POM-30 \$66,920.00	POM-30 \$66,920.00	POM-30 \$66,920.00	POM-30 \$66,920.00
40 MMBTU/h 1130 m <sup>3</sup> /h	POM-40 \$74,756.00	POM-30 \$66,920.00	POM-30 \$66,920.00	POM-30 \$66,920.00	POM-30 \$66,920.00	POM-30 \$66,920.00	POM-30 \$66,920.00	POM-30 \$66,920.00	POM-30 \$66,920.00	POM-30 \$66,920.00
60 MMBTU/h 1700 m <sup>3</sup> /h	POM-40 \$74,756.00	POM-30 \$66,920.00	POM-30 \$66,920.00	POM-30 \$66,920.00	POM-30 \$66,920.00	POM-30 \$66,920.00	POM-30 \$66,920.00	POM-30 \$66,920.00	POM-30 \$66,920.00	POM-30 \$66,920.00
80 MMBTU/h 2260 m <sup>3</sup> /h	POM-40 \$74,756.00	POM-40 \$74,756.00	POM-30 \$66,920.00	POM-30 \$66,920.00	POM-30 \$66,920.00	POM-30 \$66,920.00	POM-30 \$66,920.00	POM-30 \$66,920.00	POM-30 \$66,920.00	POM-30 \$66,920.00
100 MMBTU/h 2800 m <sup>3</sup> /h	POM-60 \$91,969.00	POM-40 \$74,756.00	POM-40 \$74,756.00	POM-30 \$66,920.00	POM-30 \$66,920.00	POM-30 \$66,920.00	POM-30 \$66,920.00	POM-30 \$66,920.00	POM-30 \$66,920.00	POM-30 \$66,920.00
120 MMBTU/h 3400 m <sup>3</sup> /h	POM-60 \$91,969.00	POM-40 \$74,756.00	POM-40 \$74,756.00	POM-40 \$74,756.00	POM-30 \$66,920.00	POM-30 \$66,920.00	POM-30 \$66,920.00	POM-30 \$66,920.00	POM-30 \$66,920.00	POM-30 \$66,920.00
140 MMBTU/h 4000 m <sup>3</sup> /h	POM-60 \$91,969.00	POM-60 \$91,969.00	POM-40 \$74,756.00	POM-40 \$74,756.00	POM-40 \$74,756.00	POM-30 \$66,920.00	POM-30 \$66,920.00	POM-30 \$66,920.00	POM-30 \$66,920.00	POM-30 \$66,920.00
160 MMBTU/h 4530 m <sup>3</sup> /h	Call Factory	POM-60 \$91,969.00	POM-40 \$74,756.00	POM-40 \$74,756.00	POM-40 \$74,756.00	POM-40 \$74,756.00	POM-30 \$66,920.00	POM-30 \$66,920.00	POM-30 \$66,920.00	POM-30 \$66,920.00
180 MMBTU/h 5100 m <sup>3</sup> /h	Call Factory	POM-60 \$91,969.00	POM-40 \$74,756.00	POM-40 \$74,756.00	POM-40 \$74,756.00	POM-40 \$74,756.00	POM-30 \$66,920.00	POM-30 \$66,920.00	POM-30 \$66,920.00	POM-30 \$66,920.00
200 MMBTU/h 5660 m <sup>3</sup> /h	Call Factory	POM-60 \$91,969.00	POM-40 \$74,756.00	POM-40 \$74,756.00	POM-40 \$74,756.00	POM-40 \$74,756.00	POM-40 \$74,756.00	POM-30 \$66,920.00	POM-30 \$66,920.00	POM-30 \$66,920.00
220 MMBTU/h 6230 m <sup>3</sup> /h	Call Factory	POM-60 \$105,846.00	POM-60 \$105,846.00	POM-40 \$88,633.00	POM-40 \$88,633.00	POM-40 \$88,633.00	POM-40 \$88,633.00	POM-40 \$88,633.00	POM-30 \$66,920.00	POM-30 \$66,920.00
240 MMBTU/h 6800 m <sup>3</sup> /h	Call Factory	POM-60 \$105,846.00	POM-60 \$105,846.00	POM-40 \$88,633.00	POM-40 \$88,633.00	POM-40 \$88,633.00	POM-40 \$88,633.00	POM-40 \$88,633.00	POM-40 \$88,633.00	POM-30 \$66,920.00
260 MMBTU/h 7360 m <sup>3</sup> /h <sup>2</sup>	Call Factory	Call Factory	POM-60 \$105,846.00	POM-60 \$105,846.00	POM-40 \$88,633.00	POM-40 \$88,633.00	POM-40 \$88,633.00	POM-40 \$88,633.00	POM-40 \$88,633.00	POM-40 \$88,633.00
280 MMBTU/h 7930 m <sup>3</sup> /h	Call Factory	Call Factory	POM-60 \$105,846.00	POM-60 \$105,846.00	POM-40 \$88,633.00	POM-40 \$88,633.00	POM-40 \$88,633.00	POM-40 \$88,633.00	POM-40 \$88,633.00	POM-40 \$88,633.00
300 MMBTU/h 8500 m <sup>3</sup> /h	Call Factory	Call Factory	POM-60 \$105,846.00	POM-60 \$105,846.00	POM-60 \$105,846.00	POM-40 \$88,633.00	POM-40 \$88,633.00	POM-40 \$88,633.00	POM-40 \$88,633.00	POM-40 \$88,633.00
320 MMBTU/h 9060 m <sup>3</sup> /h	Call Factory	Call Factory	POM-60 \$105,846.00	POM-60 \$105,846.00	POM-60 \$105,846.00	POM-40 \$88,633.00	POM-40 \$88,633.00	POM-40 \$88,633.00	POM-40 \$88,633.00	POM-40 \$88,633.00
340 MMBTU/h 9630 m <sup>3</sup> /h	Call Factory	Call Factory	Call Factory	POM-60 \$105,846.00	POM-60 \$105,846.00	POM-40 \$88,633.00	POM-40 \$88,633.00	POM-40 \$88,633.00	POM-40 \$88,633.00	POM-40 \$88,633.00
360 MMBTU/h 10200 m <sup>3</sup> /h	Call Factory	Call Factory	Call Factory	POM-60 \$105,846.00	POM-60 \$105,846.00	POM-60 \$105,846.00	POM-40 \$88,633.00	POM-40 \$88,633.00	POM-40 \$88,633.00	POM-40 \$88,633.00
380 MMBTU/h 10760 m <sup>3</sup> /h	Call Factory	Call Factory	Call Factory	POM-60 \$105,846.00	POM-60 \$105,846.00	POM-60 \$105,846.00	POM-40 \$88,633.00	POM-40 \$88,633.00	POM-40 \$88,633.00	POM-40 \$88,633.00
400 MMBTU/h 11330 m <sup>3</sup> /h	Call Factory	Call Factory	Call Factory	POM-60 \$105,846.00	POM-60 \$105,846.00	POM-60 \$105,846.00	POM-40 \$88,633.00	POM-40 \$88,633.00	POM-40 \$88,633.00	POM-40 \$88,633.00

## Options, Accessories and Spare Parts for WB/HVS Systems

The following list shows the most commonly requested options, accessories and spare parts for HVS series LPG/Air mixers. Unless listed otherwise, all parts fit all models and all model-years after 1985, except for models modified for specific applications. When ordering spare parts, please provide the serial number of your HVS Mixer.

Part Number	Description	Price in US-\$
HVSOPT-S7W	Siemens S7-1200 with 6-inch (320x240) Siemens Touch Panel with built-in Web Server for Remote Access and Control (Systems with Siemens PLC only)	\$ 2,792.00
SWI0030	Pressure switch, Low LPG; for models WB-200/HVS-14MM and WB-250/HVS-20MM;	\$ 597.70
SWI0033	Pressure switch, Tank Monitor, 2 setpoints; for models WB-200/HVS-14MM and WB-250/HVS-20MM;	\$ 788.60
SWI0029	Pressure switch, Tank Monitor, 3 setpoints; for models WB-200/HVS-14MM and WB-250/HVS-20MM;	\$ 989.50
TRA0056	Tank Monitor Pressure Transmitter; 0-30 psi, 4-20 mA; for systems with PLC controls;	\$ 1,918.00
TRA0058	Vapor Pressure Transmitter; 0-300 psi, 4-20 mA; for systems with PLC controls;	\$ 1,918.00
VAL0012M	Instrument valve (in pressure gauge line);	\$ 17.50
GAU0005	Pressure gauge; liquid filled; stainless steel case, brass internals; with case vent; 15 psi;	\$ 39.50
GAU0001	Pressure gauge; liquid filled; stainless steel case, brass internals; with case vent; 30 psi;	\$ 39.50
GAU0002	Pressure gauge; liquid filled; stainless steel case, brass internals; with case vent; 100 psi;	\$ 39.50
GAU0006	Pressure gauge; liquid filled; stainless steel case, brass internals; with case vent; 300 psi;	\$ 39.50
SOL0073	Solenoid valve, non-explosion-proof; for venturi assembly; valve can be used in "static" or "dynamic" positions in venturi line;	\$ 308.80
SOL0073R	Repair kit for solenoid non-explosion-proof solenoid valve; (includes Solenoid Coil; specify voltage DC24V or AC110V 60Hz or AC220V 50Hz);	\$ 200.60
SOL0073C	Solenoid Coil, non-explosion-proof (specify voltage DC24V or AC110V 60Hz or AC220V 50Hz);	\$ 91.10
SOL0082	Solenoid valve, explosion-proof; for venturi assembly; valve can be used in "static" or "dynamic" positions in venturi line;	\$ 448.60
SOL0082R	Repair kit for solenoid explosion-proof solenoid valve; (includes Solenoid Coil; specify voltage DC24V or AC110V 60Hz or AC220V 50Hz);	\$ 291.40
SOL0082C	Solenoid Coil, explosion-proof; (specify voltage DC24V or AC110V 60Hz or AC220V 50Hz);	\$ 132.30
VAL0002	Valve Assembly, Air Intake, complete; includes valve body, back plate, check plate, bronze bearing sleeve, gasket, Venturi Nozzle (specify "C" for 7MM or "D" for 10MM with order), O-rings, self-locking nut, stainless steel spring, spring retainer;	\$ 1,660.20
VAL0084	Check valve: backplate for air intake;	\$ 247.00
VAL0085	Check valve: check-plate for air intake;	\$ 258.10
GAS0014	Check valve: gasket for air intake;	\$ 15.00
SPR0001	Check valve: spring, stainless steel	\$ 62.00
NOZ0003	Venturi Nozzle, Type "C";	\$ 691.80
NOZ0004	Venturi Nozzle, Type "D";	\$ 691.80
VEN0001	Venturi Tube, Type "M";	\$ 1,221.70
VEN0002	Venturi Tube, Type "N";	\$ 1,221.70
NOZ0007	Venturi Nozzle, Type "E";	\$ 816.30
NOZ0008	Venturi Nozzle, Type "F";	\$ 816.30
VEN0009	Venturi Tube, Type "O";	\$ 1,346.20
VEN0010	Venturi Tube, Type "P";	\$ 1,346.20
REG0006	Regulator in vapor supply line to Venturi Mixer;	\$ 548.40
REG0006R	Repair Kit for regulator in vapor supply line to Venturi Mixer;	\$ 188.60

For Options, Accessories and Spare Parts for Water Bath Vaporizers, please refer to price list "Water Bath LPG Vaporizers".



WB-450/HVS-40 with Enlarged Control Room / Maintenance House

### Enlarged Control Room / Maintenance House

All AES Water Bath Vaporizer / LP-Air Mixing Systems (WB/HVS and WB/POM) can be equipped with an enlarged system control room, sometimes referred to as the maintenance house. These enlarged control offer operators and maintenance personnel additional weather protection, as well as additional room for monitoring, recording, and control components. They are typically as wide as the vaporizer/mixer skid and approximately 8 ft (2.4 m) long, but can be built to meet any specific requirements. They are equipped with light fixture, AC outlet, electric heater, and GasLeak Monitor. Air conditioning units of various capacities are available as options.

For pricing and available options, or to discuss your specific requirements, please contact the factory or your nearest AES distributor.

## HVS LPG-Vapor / Air Mixers with Water Bath Vaporizers

Model Numbers are WB-168/HVS-14 to WB-3000/HVS-250. The first part of the model number indicates the vaporizer capacity in gallons per hour; the second part indicates the mixer capacity in MMBTU per hour. All systems combine horizontal water bath vaporizers (08-series or 05-series) with Venturi-type mixing systems (HVS-series). They come complete with vaporizer, venturi mixer, surge tank, interconnecting piping, electrical and safety controls, and are mounted on a common steel skid. This design concept makes them very compact, easy to install and to maintain, and very reliable.

All systems are factory-tested prior to shipping. After placing a system on a non-combustible surface (i.e. concrete pad), filling the vaporizer with heat transfer solution, and connecting it to electrical supply, liquid gas supply, and mixed gas outlet, it is immediately ready to produce high-quality gas which is directly compatible and interchangeable with NatGas.

Standard design output pressure is 5 to 8 psi, or 9 to 12 psi (please specify desired output pressure with order). Higher pressures up to 40 psi are also available and require compressed air for operation. In system with High Pressure Option, the surge tank is ASME U-stamped.

All WB/HVS systems monitor the gas pressure in the surge tank, using a pressure transmitter that is connected to a Siemens or Allen-Bradley PLC. The PLC, which is shared with the vaporizer, "sequences" the venturi lines and controls all mixer safety functions. The PLC also communicates with a color LCD display with Touch Screen Operator Interface, displaying system pressures, and any trouble conditions that may occur.

The WB/HVS series is designed for outdoor installation and requires only nominal preventive maintenance. Intended for intermittent service (see Note), the systems are manufactured to meet or exceed requirements of the ASME Pressure Vessel Code Section VIII, and the latest edition of NFPA Pamphlet #58. They are approved by Factory Mutual (FM) and Canadian Standards Association (CSA), and are suitable for Industrial Risk Insurers (IRI) installations.

All systems are factory tested, primed, painted and ready for installation. They come with 2 sets of operating manuals and test reports. All vaporizers are equipped with "smart" Liquid Carryover Protection.

All HVS Mixers are equipped with two solenoid valves per venturi train. The "dynamic" solenoid valve opens and closes each time a venturi train is activated to produce mixed gas. The "static" solenoid valves opens when the mixer is started and stays open until the mixer is stopped, or until a high-pressure alarm occurs. This feature provides an additional level of safety, and prevents the unwanted discharge of mixed gas in case of a failure of the "dynamic" solenoid valve.

The mixer sendout pressure and the sequencing of the venturi lines (differential pressure between trains; ON-OFF deadband) can be adjusted through simple inputs at the touch screen. A separate "Venturi Cycle Counter" for each venturi train increments each time a venturi train is activated. This information can be used to determine when the mechanical components of a venturi train should be closely inspected, overhauled, or replaced.

The required vapor supply pressure depends on the desired sendout pressure, on the type of available LPG (Propane/Butane content), and on other factors (i.e. altitude). Typical supply pressures for "Propane" and 5-8 psi sendout pressure are 30-60 psi. Systems with higher sendout pressure of 9-12 psi require considerably higher vapor supply pressure, which can be difficult to maintain in very cold climates. Mixed Gas Sendout Pressures of more than 12 psi require the High Pressure option, which includes a surge tank with ASME "U"-Stamp.

Please Note: Venturi-based LP/Air mixers are generally considered "for intermittent use". Due to the relatively limited useful life of their dynamically exercised mechanical components (regulators, check valves, solenoid valves, air intake valves, etc. are typically specified by their respective manufacturers to withstand 200000 to 500000 cycles), they are not very well suited for baseload applications. Their main application is "Emergency Backup".

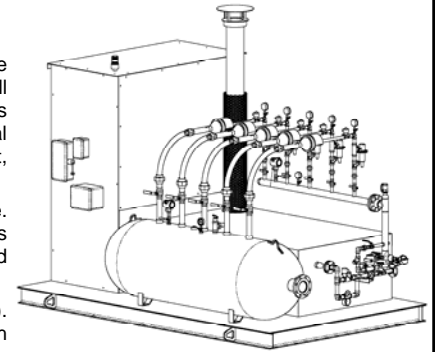

Model Number	Nominal Capacity MMBTU	Number of Venturis <sup>1</sup>	Surge Tank Capacity US-gal (m <sup>3</sup> )	Approximate Skid Size in inches (m)	Price in US-\$ 5 to 8 psi	Price in US-\$ 9 to 12 psi	Price in US-\$ High Press.
WB - 168 / HVS - 14 MM	14	2	120 (0.450)	W = 84 (2.13) L = 135 (3.43) H = 100 (2.54)	\$ 42,800.00	N/A	\$ 4,813.00
WB - 208 / HVS - 17 MM	17	2	120 (0.450)		\$ 44,800.00	N/A	\$ 4,813.00
WB - 258 / HVS - 20 MM	20	2	120 (0.450)		\$ 48,800.00	\$ 52,490.00	\$ 4,813.00
WB - 308 / HVS - 27 MM	27	3	120 (0.450)		\$ 59,860.00	N/A	\$ 6,724.00
WB - 358 / HVS - 30 MM	30	3	120 (0.450)		\$ 61,860.00	\$ 67,400.00	\$ 6,724.00
WB - 408 / HVS - 37 MM	37	4	120 (0.450)		\$ 71,390.00	N/A	\$ 8,413.00
WB - 458 / HVS - 40 MM	40	4	120 (0.450)	\$ 72,890.00	\$ 80,270.00	\$ 8,413.00	
WB - 555 / HVS - 50 MM	50	5	250 (0.950)	W = 98 (2.49) L = 158 (4.01) H = 100 (2.54)	\$ 97,739.00	\$106,969.00	\$ 9,908.00
WB - 755 / HVS - 60 MM	60	6	250 (0.950)		\$ 117,364.00	\$128,440.00	\$ 11,599.00
WB - 855 / HVS - 70 MM	70	7	250 (0.950)		\$ 127,537.00	\$140,459.00	\$ 13,289.00
WB - 1005 / HVS - 80 MM	80	8	500 (1.893)	W = 107 (2.72) L = 198 (5.03) H = 100 (2.54)	\$ 142,410.00	\$157,178.00	\$ 14,787.00
WB - 1005 / HVS - 90 MM	90	9	500 (1.893)		\$ 151,478.00	\$168,092.00	\$ 16,695.00
WB - 1205 / HVS - 100 MM	100	10	500 (1.893)		\$ 164,753.00	\$183,213.00	\$ 18,386.00
WB - 1505 / HVS - 110 MM	110	11	500 (1.893)		\$ 181,457.00	\$201,763.00	\$ 20,077.00
WB - 1505 / HVS - 120 MM	120	12	500 (1.893)		\$ 186,034.00	\$208,186.00	\$ 22,745.00
WB - 1505 / HVS - 130 MM	130	13	500 (1.893)		\$ 192,526.00	\$216,524.00	\$ 24,435.00
WB - 1805 / HVS - 140 MM	140	14	500 (1.893)		\$ 211,564.00	\$237,408.00	\$ 26,126.00
WB - 1805 / HVS - 150 MM	150	15	500 (1.893)		\$ 217,476.00	\$245,166.00	\$ 27,816.00
WB - 2005 / HVS - 160 MM	160	16	500 (1.893)		\$ 238,847.00	\$268,383.00	\$ 29,311.00
WB - 2005 / HVS - 170 MM	170	17	1000 (3.785)		\$ 245,373.00	\$276,755.00	\$ 31,002.00
WB - 2005 / HVS - 180 MM	180	18	1000 (3.785)	W = 107 (2.72) L = 198 (5.03) H = 100 (2.54)	\$ 257,145.00	\$290,373.00	\$ 32,693.00
WB - 2205 / HVS - 190 MM	190	19	1000 (3.785)		\$ 267,350.00	\$302,424.00	\$ 34,189.00
WB - 2205 / HVS - 200 MM	200	20	1000 (3.785)		\$ 273,398.00	\$310,318.00	\$ 35,877.00
WB - 2505 / HVS - 210 MM	210	21	1000 (3.785)	\$ 293,476.00	\$332,242.00	\$ 38,742.00	
WB - 2505 / HVS - 220 MM	220	22	1000 (3.785)	\$ 305,181.00	\$345,793.00	\$ 40,431.00	
WB - 3005 / HVS - 230 MM	230	23	1000 (3.785)	call factory	\$ 322,727.00	\$365,185.00	\$ 41,927.00
WB - 3005 / HVS - 240 MM	240	24	1000 (3.785)	call factory	\$ 329,254.00	\$373,558.00	\$ 43,617.00
WB - 3005 / HVS - 250 MM	250	25	1000 (3.785)	call factory	\$ 341,009.00	\$387,159.00	\$ 45,309.00

<sup>1</sup> Actual number of venturi arrangements may vary with mixed gas pressure.

Weights and dimensions are approximate. Specifications are subject to change without notice. Call factory or distributor for price quotation and actual lead times.

## Options, Accessories for WB/POM Systems

The following list shows the most commonly requested options, accessories and spare parts for the WB/POM series of Water Bath Vaporizers and LPG/Air mixers. Unless listed otherwise, all options and accessories fit all vaporizer/blender models, except for models that have been modified for specific applications.

Part Number	Description	Price in US-\$
GB-3	Option: GraviBlend™-3, Gravimeter for LPG/Air mixtures, Standard Configuration for non-classified areas, Range 0.2 ... 2.2 (relative density). High-speed, high-accuracy, on-line gravimeter; measures and indicates specific gravity of mixed gas.  Powder coated steel NEMA 4 wall-mount enclosure; integrated filter element in sample gas line; integrated consumption jet in sample gas line; integrated sample gas bypass with precision instrument valve; full-graphic color LCD display with touch screen operator interface (see Note 1); direct display of Specific Gravity, Calorific Value, and Wobbe Index number; electronic signal processor (see Note 1) with alarm contacts; internally powered analog output signal 4...20 mA (source; scaled to 0.4 ... 2.0 SG) for external recording instruments; AC110V 60Hz or AC220V 50Hz; graphic trend recording function; semi-automatic calibration feature.	\$16,934.00
GB-3E	Option: GraviBlend™-3E, Gravimeter for LPG/Air mixtures, Explosion-Proof Configuration for classified areas, Range 0.2 ... 2.2 (relative density). High-speed, high-accuracy, on-line gravimeter; measures and indicates specific gravity of mixed gas. Separate enclosures for electronic components, gas distribution elements, and density sensor.  Electronics Enclosure (see Note 1): powder coated steel NEMA 4 wall-mount enclosure; full-graphic color LCD display with touch screen operator interface; direct display of Specific Gravity, Calorific Value, and Wobbe Index number; electronic signal processor (see Note 1) with alarm contacts; internally powered analog output signal 4...20 mA (source; scaled to 0.4 ... 2.0 SG) for external recording instruments; AC110V 60Hz or AC220V 50Hz; graphic trend recording function; semi-automatic calibration feature.  Gas Distribution Enclosure: powder coated steel NEMA 4 wall-mount enclosure; integrated filter element in sample gas line; integrated consumption jet in sample gas line; integrated sample gas bypass with precision instrument valve; 1/8" bulkhead fittings for connection to Sensor Enclosure.  Sensor Enclosure: explosion-proof aluminum junction box with density sensor and signal conditioner, wall-mount (horizontally).	\$21,914.00
WBPOMACC	Option: AccuBlend™ System, Automatic Gas Properties Control. Electric actuator to adjust the angular position of the piston in the POM, and thereby correcting the calorific value of the mixed gas. Actuator is installed on top of the POM valve. Price includes proportional controller (integrated in electronic signal processor of GraviBlend™-3/3E; see Note 1), which receives a linear analog signal (4-20 mA or 0-5V) from the Gravimeter and sends a control signal to the actuator (requires "Option: Gravimeter").	\$8,855.00
WBPOMETH	Siemens S7-1200 with 10-inch (640x480) Siemens Touch Panel with built-in Web Server for Remote Access and Control. System can be accessed with a standard web browser. No special software required.	\$3,834.00
WBPOMFLOW	Flow Transmitter in sendout line; real-time SNG flow display on EOI. If the POM is equipped with a Gravimeter, LPG vapor flow, compressed air flow, and liquid LPG flow are also displayed. Dual Flow Totalizer (with individual reset) is standard for all displayed flow values.	\$7,909.00
WBPOMTEM	Option: Three Temperature Transmitters; installed in vapor supply, air supply line, and mixed gas line. Each transmits a 4-20 mA signal to the PLC in the system control panel. Temperature display in engineering units, i.e. °F or °C. Includes Hi/Lo alarm setpoints for each transmitter; includes expansion analog input module for PLC.	\$3,862.00
WBPOMMOD	Option: Module Unit. Installation of POM on same skid with water bath vaporizer. POM orientation is "vertical".	\$4,903.00
WBPOMEX2	Option: Ex-proof control components; required for installations where the POM is more than 15 ft. away from a gas-fired vaporizer (U.S. rules), or where required by local law. Includes explosion-proof pressure transmitters in vapor supply line, air supply line, and mixed gas line. Interconnecting cable between explosion proof junction box at the blender skid and the vaporizer/blender control panel in the vaporizer control room is to be supplied and installed at job site. Maximum distance between blender and vaporizer approximately 2000 ft. (600 m). Includes local Start/Stop station, installed on blender skid.	\$6,076.00
WBPOMCE-1	Option: CE Approval for vaporizer and blender; compliant with PED, ATEX, and all other applicable European Directives; WB-168/POM-10 to WB-408/POM-40	\$8,743.00
WBPOMCE-2	Option: CE Approval for vaporizer and blender; compliant with PED, ATEX, and all other applicable European Directives; WB-458/POM-30 to WB-855/POM-40	\$9,679.00
WBPOMCE-3	Option: CE Approval for vaporizer and blender; compliant with PED, ATEX, and all other applicable European Directives; WB-1005/POM-30 to WB-2205/POM-60	\$10,172.00
WBPOMCE-4	Option: CE Approval for vaporizer and blender; compliant with PED, ATEX, and all other applicable European Directives; WB-2505/POM-40 to WB-5505/POM-60	\$12,066.00
POMPKSHV	Option: Electronic PeakShaving Controller. Includes PLC upgrades (10- or 12-inch color LCD display with Touch Screen Operator Interface; Analog Output for Flow Control Valve). Includes user-selectable PeakShaving modes (i.e. "Inject fixed SNG Volume"; "Limit NG Flow"; "Maintain NG/SNG Ratio"; ...). Includes electronically controlled Flow Control Valve in Mixed Gas Sendout Line (pneumatically actuated); Flow Transmitter in Mixed Gas Sendout Line; Analog Inputs for Grid Flow (or NatGas Flow), and Grid Pressure; block valve in Mixed Gas Sendout Line (pneumatically actuated).	Call Factory

Note 1: If the GraviBlend™-3/3E gravimeter is ordered together with a WB/POM system, the electronic signal processor of the gravimeter will be integrated into the PLC of the WB/POM system. The electronic operator interface will be a 7-inch high-resolution color LCD display with touch screen operator interface. An upgrade to a 10-inch Siemens MP277 or Allen-Bradley PanelView-Plus is available at a nominal charge of US-\$2,800.00.

## Piston Operated Mixers (POM) with Water Bath Vaporizers

Model Numbers are WB-168/POM-10 to WB-3000/POM-60. The first part of the model number indicates the vaporizer capacity in gallons per hour, the second part indicates the mixer size (10 - 30 - 40 - 60). All systems combine horizontal water bath vaporizers (08-series or 05-series) with our patented Piston Operated Mixer (POM-series). They can be ordered for installation as individual units (water bath vaporizer and mixer within 15 ft [4.5m] of each other), or as a very compact "Module Unit" (see options), with the POM in "vertical" orientation and installed on the same skid with the vaporizer. In Module Units, all piping between the vaporizer and the blender, and all wiring between the blender and the control panel, are factory-installed, which can reduce installation time considerably. Both versions are equally reliable and have set the standard for value, reliability, ease-of-use, low maintenance, and high availability, in many different applications in many different countries, surpassing other high-capacity / high-pressure blender concepts by far.

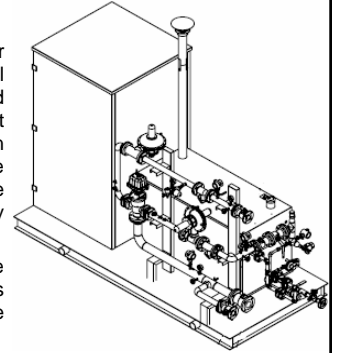

To select the correct vaporizer/blender combination, first determine the required vaporizer capacity by adding up the connected load. Including a safety factor of 1.1 to 1.3, select the vaporizer model. The capacity of the POM mixer depends on its configuration and the system pressure. In the table below, after selecting the vaporizer model, move to the right to the desired discharge pressure to find the POM model number and the price for the vaporizer/blender combination.

All WB/POM systems share the control panel between the WB vaporizer and the POM blender. The standard PLC is a Siemens S7-1200, or an Allen-Bradley MicroLogix-1100. Both PLCs have a built-in Ethernet Interface, and communicate with an Electronic Operator Interface (EOI) with high-resolution color LCD display and Touch Screen. Electrical connections between the POM blender and the control panel are made in two different ways:

In Module Units (POM blender on same skid with vaporizer), electrical connections run from the blender directly to the control panel. In individual units, all electrical connections are terminated in an explosion proof junction box at the POM skid. From there, a multi-wire cable (not included with system) is run to the mixer control panel in the vaporizer control room.

The WB/POM Series is designed for outdoor installation and requires only nominal preventive maintenance. Intended for intermittent or continuous service, the systems are manufactured to meet or exceed requirements of the ASME Pressure Vessel Code Section VIII, and the latest edition of NFPA Pamphlet #58. They are approved by Factory Mutual (FM) and Canadian Standards Association (CSA), and are suitable for Industrial Risk Insurers (IRI) installations. All systems are factory tested, primed, painted and ready for installation. They come with 2 sets of operating manuals and test reports.

All vaporizers in WB/POM systems are equipped with Rosemount Pressure and Temperature Transmitters in the Vapor Outlet of the vaporizer for "smart" Liquid Carryover Protection, based on pressure/temperature correlation and LPG type (Propane/Butane/...).

Nominal Capacity in BTU per hour and NatGas Equivalent\*\* (m<sup>3</sup>/h; in bottom row) is strictly based on the vaporization capacity of the vaporizer, and is given for Propane/Air mixtures with 1450 BTU/cuft at delivered mixed gas pressures of 10 psig (0.7 bar) to 70 psig (5 bar). Capacity for other LPG/Air mixtures and/or pressures may vary. Nominal Capacity is based on vapor and compressed air inlet pressures of 100-125 psig, and a pressure drop of 10% across the mixing valve at maximum flow. The minimum vapor and air supply pressures are "Sendout Pressure + 15 psi (1bar)".

Other Vaporizer/Blender configurations (for lower or higher delivery pressures, higher flow rates, other blending gasses, different materials, ...) are available. Please contact the factory or your area distributor for details.

\*\* NatGas Equivalent: In most cases, these systems will be used to provide backup for a NatGas supply. Including a sufficient safety factor (1.1 ... 1.3), use the maximum expected NatGas flow per hour to select the correct WB/POM model.

Vaporizer Model	Nominal Capacity**	System Discharge Pressure						
		10 psi	20 psi	30 psi	40 psi	50 psi	60 psi	70 psi
WB-168	15 MMBTU/h	POM-30	POM-30	POM-10	POM-10	POM-10	POM-10	POM-10
	424 m <sup>3</sup> /h	\$90,920.00	\$90,920.00	\$76,370.00	\$76,370.00	\$76,370.00	\$76,370.00	\$76,370.00
WB-208	19 MMBTU/h	POM-30	POM-30	POM-10	POM-10	POM-10	POM-10	POM-10
	538 m <sup>3</sup> /h	\$92,920.00	\$92,920.00	\$78,370.00	\$78,370.00	\$78,370.00	\$78,370.00	\$78,370.00
WB-258	24 MMBTU/h	POM-30	POM-30	POM-10	POM-10	POM-10	POM-10	POM-10
	679 m <sup>3</sup> /h	\$96,920.00	\$96,920.00	\$82,370.00	\$82,370.00	\$82,370.00	\$82,370.00	\$82,370.00
WB-308	28 MMBTU/h	POM-30	POM-30	POM-30	POM-30	POM-30	POM-30	POM-30
	792 m <sup>3</sup> /h	\$99,920.00	\$99,920.00	\$99,920.00	\$99,920.00	\$99,920.00	\$99,920.00	\$99,920.00
WB-358	33 MMBTU/h	POM-30	POM-30	POM-30	POM-30	POM-30	POM-30	POM-30
	934 m <sup>3</sup> /h	\$101,920.00	\$101,920.00	\$101,920.00	\$101,920.00	\$101,920.00	\$101,920.00	\$101,920.00
WB-408	37 MMBTU/h	POM-40	POM-30	POM-30	POM-30	POM-30	POM-30	POM-30
	1047 m <sup>3</sup> /h	\$111,256.00	\$103,420.00	\$103,420.00	\$103,420.00	\$103,420.00	\$103,420.00	\$103,420.00
WB-458	42 MMBTU/h	POM-40	POM-30	POM-30	POM-30	POM-30	POM-30	POM-30
	1189 m <sup>3</sup> /h	\$112,756.00	\$104,920.00	\$104,920.00	\$104,920.00	\$104,920.00	\$104,920.00	\$104,920.00
WB-508	47 MMBTU/h	POM-40	POM-30	POM-30	POM-30	POM-30	POM-30	POM-30
	1330 m <sup>3</sup> /h	\$115,756.00	\$107,920.00	\$107,920.00	\$107,920.00	\$107,920.00	\$107,920.00	\$107,920.00
WB-555	51 MMBTU/h	POM-40	POM-30	POM-30	POM-30	POM-30	POM-30	POM-30
	1444 m <sup>3</sup> /h	\$122,291.00	\$114,456.00	\$114,456.00	\$114,456.00	\$114,456.00	\$114,456.00	\$114,456.00
WB-655	60 MMBTU/h	POM-40	POM-30	POM-30	POM-30	POM-30	POM-30	POM-30
	1699 m <sup>3</sup> /h	\$126,082.00	\$118,245.00	\$118,245.00	\$118,245.00	\$118,245.00	\$118,245.00	\$118,245.00
WB-755	69 MMBTU/h	POM-40	POM-30	POM-30	POM-30	POM-30	POM-30	POM-30
	1953 m <sup>3</sup> /h	\$131,248.00	\$123,412.00	\$123,412.00	\$123,412.00	\$123,412.00	\$123,412.00	\$123,412.00
WB-855	79 MMBTU/h	POM-40	POM-40	POM-30	POM-30	POM-30	POM-30	POM-30
	2237 m <sup>3</sup> /h	\$134,341.00	\$134,341.00	\$126,504.00	\$126,504.00	\$126,504.00	\$126,504.00	\$126,504.00
WB-1005	92 MMBTU/h	POM-40	POM-40	POM-30	POM-30	POM-30	POM-30	POM-30
	2605 m <sup>3</sup> /h	\$142,777.00	\$142,777.00	\$134,941.00	\$134,941.00	\$134,941.00	\$134,941.00	\$134,941.00
WB-1205	111 MMBTU/h	POM-60	POM-40	POM-40	POM-30	POM-30	POM-30	POM-30
	3143 m <sup>3</sup> /h	\$165,613.00	\$148,398.00	\$148,398.00	\$140,563.00	\$140,563.00	\$140,563.00	\$140,563.00
WB-1505	139 MMBTU/h	POM-60	POM-40	POM-40	POM-40	POM-40	POM-30	POM-30
	3936 m <sup>3</sup> /h	\$174,099.00	\$156,885.00	\$156,885.00	\$156,885.00	\$156,885.00	\$159,643.00	\$159,643.00
WB-1805	166 MMBTU/h	Consult	POM-60	POM-40	POM-40	POM-40	POM-40	POM-30
	4700 m <sup>3</sup> /h		\$184,974.00	\$167,761.00	\$167,761.00	\$167,761.00	\$167,761.00	\$170,518.00
WB-2005	185 MMBTU/h		POM-60	POM-40	POM-40	POM-40	POM-40	POM-30
	5238 m <sup>3</sup> /h		\$199,082.00	\$181,867.00	\$181,867.00	\$181,867.00	\$181,867.00	\$184,625.00
WB-2205	203 MMBTU/h		POM-60	POM-40	POM-40	POM-40	POM-40	POM-40
	5748 m <sup>3</sup> /h		\$202,658.00	\$185,444.00	\$185,444.00	\$185,444.00	\$185,444.00	\$185,444.00
WB-2505	231 MMBTU/h		POM-60	POM-60	POM-40	POM-40	POM-40	POM-40
	6541 m <sup>3</sup> /h		\$229,242.00	\$229,242.00	\$212,028.00	\$212,028.00	\$212,028.00	\$212,028.00
WB-3005	277 MMBTU/h			POM-60	POM-60	POM-40	POM-40	POM-40
	7843 m <sup>3</sup> /h			\$238,455.00	\$238,455.00	\$221,241.00	\$221,241.00	\$221,241.00

The table above shows WB/POM combinations for standard Propane. Configurations for other LPG mixtures may vary. Specifications are subject to change without notice. Call factory or distributor for price quotation and actual lead times.

## Flare Burner Heads (Test Flares)

Test Flares are used during system setup, and for periodical system tests and maintenance. They represent large loads, and allow the system to be tested under simulated load conditions.

AES manufactures standard test flares with 1" gas line, 2" gas line, and 3" gas line. Other flares for specific systems are available as customer specials. All AES test flares are equipped with automatic ignition, standing pilot, stainless steel parts, Electronic Flame Safeguard, and electric solenoid (or pneumatically actuated) main flare gas valve. Flame Arrestors with flanged connections, 304 stainless-steel body, and 316L stainless steel element, are available as an option.

Model Number	Size	Shipping Weight	Price in US-\$	Flame Arrester
FH-1	1"	200 lbs.	\$ 6,923.00	\$ 3,907.00 (2-inch)
FH-2	2"	250 lbs.	\$ 8,760.00	\$ 4,309.00 (3-inch)
FH-3	3"	390 lbs.	\$ 10,529.00	\$ 5,010.00 (4-inch)

Weights and dimensions are approximate. Specifications are subject to change without notice. Call factory or distributor for price quotation and actual lead times.

### Approximate Theoretical Flare Burner Capacities

	@ 5 psi	@ 10 psi	@ 15 psi	@ 30 psi	@ 50 psi
FH-1	25 MMBTU/h	33 MMBTU/h	44 MMBTU/h	76 MMBTU/h	88 MMBTU/h
FH-2	36 MMBTU/h	72 MMBTU/h	101 MMBTU/h	188 MMBTU/h	304 MMBTU/h
FH-3	108 MMBTU/h	196 MMBTU/h	290 MMBTU/h	522 MMBTU/h	841 MMBTU/h

Capacities are approximate and are based on flare stack distance of ~50 ft. from mixer discharge location and minimum pressure of 2 psig at the flare stack.

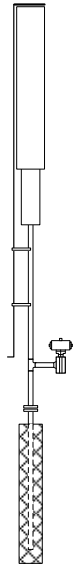

## Coalescing LPG Vapor Filters

All AES vaporizers are equipped with strainers in the liquid LPG supply line. These strainers are designed to remove solid contaminants from the LPG, i.e. sand or rust. However, in order to remove moisture and unwanted by-products from the refining process of the LPG, so-called "heavy ends", from the LPG, a coalescing filter is required. AES manufactures coalescing filters for the vapor phase (PVF series) that are specifically designed for this purpose.

The filters are available in various sizes, and are all equipped with a manual drain for the removal of accumulated contaminants, and a differential pressure gauge. All filters are designed for 250 psi operating pressure at 650°F (17.2 bar @ 343°C). Filters above 6 inch vessel ID are shipped with ASME "U"-Stamp. The ASME "U"-Stamp is available as an option for the smaller filters. All filters have flanged inlet and outlet connections (ANSI or DIN), and can be opened for inspection and maintenance.

All filters should be installed with a maintenance bypass around them.

AES PVF Coalescing Filters are painted "Gas-Yellow" (RAL 1017).

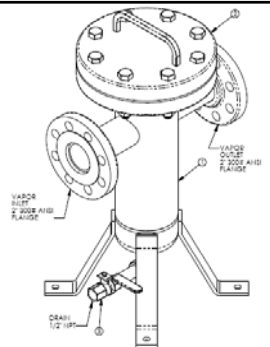

### Coalescing Vapor Filters

Model Number	PVF 010104	PVF 020204	PVF 020206	PVF 030306	PVF 040408
Nominal Flow Capacity	250 gph / 500 kg/h	500 gph / 1000 kg/h	800 gph / 1600 kg/h	1200 gph / 2400 kg/h	2500 gph / 5000 kg/h
Inlet Size	1-inch / DN25	2-inch / DN100	2-inch / DN100	3-inch / DN80	4-inch / DN100
Outlet Size	1-inch / DN25	2-inch / DN100	2-inch / DN100	3-inch / DN80	4-inch / DN100
Vessel Diameter	4-inch / DN100	4-inch / DN100	6-inch / DN150	6-inch / DN150	8-inch / DN200
Overall Dimensions, W	16 inches / 0.41 m	16 inches / 0.41 m	18 inches / 0.46 m	18 inches / 0.46 m	22 inches / 0.56 m
Overall Dimensions, H	40 inches / 1.02 m	46 inches / 1.17 m	46 inches / 1.17 m	46 inches / 1.17 m	56 inches / 1.42 m
Shipping Weight	135 lbs / 61 kg	150 lbs / 68 kg	220 lbs / 100 kg	250 lbs / 113 kg	390 lbs / 177 kg
Price	\$ 4,350.00	\$ 5,310.00	\$ 6,130.00	\$ 6,840.00	\$ 8,670.00
ASME "U"-Stamp	\$ 1,107.00	\$ 1,107.00	\$ 1,107.00	\$ 1,107.00	included

All specifications are subject to change without notice. Weights and dimensions are approximate. Call factory or distributor for price quotation and actual lead times.  
Nominal Flow Capacity is based on 20 psi / 1.4 bar vapor pressure. Higher vapor pressures may increase the actual flow capacity. Lower vapor pressures will decrease the actual flow capacity.

## Truck Unload Stations and Forklift Cylinder Fill Stations

Truck Unload Stations are used to transfer LPG from supply trucks to the storage tank(s). AES truck unload stations are designed to be anchored in a concrete foundation. They come complete with liquid transfer connection and vapor return connection. They are equipped with block valves, excess flow valves, vent valves, backcheck valves, and breakaway couplings. Emergency Shutoff Valves (ESV) with pull cable and Nitrogen-operated ESV are available as an option.

Cylinder fill stations, i.e. for filling of forklift cylinders, can be supplied separately, or integrated with the truck unload station. The price shown below is for a station that is integrated with a Truck Unload Station.

Model Number	Description, Size	Shipping Weight	Price in US-\$
TUS-2	Truck Unload Station, 2" x 1¼"	430 lbs.	\$ 6,575.00
TUS-3	Truck Unload Station, 3" x 2"	490 lbs.	\$ 10,408.00
CFS-1	Forklift Cylinder Fill Station	80 lbs.	\$ 3,334.00
MIS-1	Methanol Injection System for TUS-2	90 lbs.	\$ 2,602.00
MIS-2	Methanol Injection System for TUS-3	120 lbs.	\$ 3,382.00

Prices for Truck Unload Stations do not include Emergency Shutoff Valves with Safety Handle.

Price for Cylinder Fill Station is for integrated unit (with TUS-2 or TUS-3) and does not include fill hose or nozzle.

Weights and dimensions are approximate. Specifications are subject to change without notice. Call factory or distributor for price quotation and actual lead times.

## LPG Transfer Pumps

LPG Transfer Pumps, as the name implies, are used to transfer LPG from the storage tanks to the vaporizer. In systems with venturi LPG/air mixing systems, they are also responsible for maintaining the pressure needed for optimum and efficient function of the venturi mixers.

AES uses pumps from the two leading manufacturers, Blackmer and Corken.

All pumps are mounted on steel skids, and are primed and painted. They are equipped with constant pressure regulator, strainer, isolation valves, summer bypass loops, liquid filled pressure gauges, and other components that are required for safe operation.

Smaller pumps up to 23/26 GPM are for single phase AC115/230V 60Hz service.

Larger pumps are for 3-phase AC230/460V 60Hz and require external motor starters. All pumps are also available for 50Hz service (AC230V 50Hz single phase; AC380/400/415V 50Hz 3-phase). Pumps up to 31 GPM are direct drive pumps (electric motor directly coupled to pump). Larger pumps are belt driven.

Dual Pump Systems are manufactured as two single pumps. Except for the common skid, they do not share any essential components (maximum redundancy). The pumps in dual pump systems can be used in any combination: Pump 1, Pump 2, or Pump 1 and Pump 2 together.

If pump systems are integrated with the vaporizer or vaporizer/blender controls, a start/stop station in an explosion-proof enclosure is installed directly at the pump skid. Integrated pumps can also be equipped with an automatic start/stop function in response to the pressure in the storage tank(s). The price adder for these options is shown below (in the "Motor Starters" section).

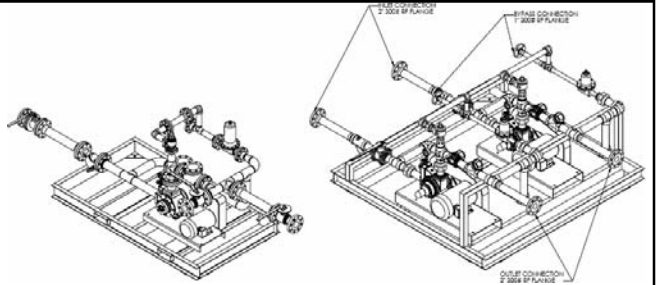

Model Number	Nominal Capacity	Max. <sup>1</sup> Syst. Size (MMBTU/h)	Pump Type	Motor HP/RPM	Drive Type	Electrical Supply	Shipping Weight (lbs / kg)	Price in US-\$ Single Pump Package	Price in US-\$ Duplex Pump Package	
<b>Blackmer Pump Packages</b>										
AEP - 5 B	5 gpm	10	LGF1	1.0 / 1750	Direct	AC115/230V 1-Ph	320 / 146	\$8,564.00	\$ 15,134.00	
AEP - 9 B	9 gpm	20	LGF1P	1.5 / 1750	Direct	AC115/230V 1-Ph	340 / 155	\$9,132.00	\$ 16,274.00	
AEP - 15 B	15 gpm	30	LGLF1.25	3.0 / 1750	Direct	AC230/460V 3-Ph	410 / 186	\$9,797.00	\$ 17,602.00	
AEP - 23 B	23 gpm	50	LGL1.5	3.0 / 1750	Direct	AC230/460V 3-Ph	410 / 186	\$11,603.00	\$ 20,529.00	
AEP - 45 B	45 gpm	100	LGLD2	5.0 / 520	Belt	AC230/460V 3-Ph	650 / 295	\$18,541.00	\$ 30,459.00	
AEP - 58 B	58 gpm	130	LGLD3	7.5 / 420	Belt	AC230/460V 3-Ph	1280 / 581	\$21,806.00	\$ 36,307.00	
AEP - 75 B	75 gpm	160	LGLD3	10 / 520	Belt	AC230/460V 3-Ph	1320 / 599	\$22,489.00	\$ 37,676.00	
AEP - 112 B	112 gpm	240	LGLD4	15 / 420	Belt	AC230/460V 3-Ph	1570 / 713	\$33,772.00	\$ 60,221.00	
AEP - 150 B	150 gpm	300	LGLD4	15 / 520	Belt	AC230/460V 3-Ph	1570 / 713	\$33,772.00	\$ 60,221.00	
<b>Corken Pump Packages</b>										
AEP - 12 C	12 gpm	25	C12	1.0 / 3450	Direct	AC115/230V 1-Ph	310 / 141	\$9,235.00	\$ 16,238.00	
AEP - 16 C	16 gpm	30	C13	2.0 / 3450	Direct	AC115/230V 3-Ph	350 / 159	\$10,136.00	\$ 18,037.00	
AEP - 26 C	26 gpm	50	C14	3.0 / 3450	Direct	AC230/460V 3-Ph	370 / 168	\$10,744.00	\$ 19,251.00	
AEP - 29 C	29 gpm	60	521	3.0 / 420	Belt	AC230/460V 3-Ph	670 / 304	\$17,792.00	\$ 30,328.00	
AEP - 40 C	40 gpm	80	521	5.0 / 520	Belt	AC230/460V 3-Ph	720 / 327	\$18,211.00	\$ 31,166.00	
AEP - 53 C	53 gpm	110	521	5.0 / 640	Belt	AC230/460V 3-Ph	720 / 327	\$18,211.00	\$ 31,166.00	
AEP - 60 C	60 gpm	130	1021	7.5 / 350	Belt	AC230/460V 3-Ph	1340 / 608	\$22,465.00	\$ 39,673.00	
AEP - 68 C	68 gpm	150	1021	10 / 350	Belt	AC230/460V 3-Ph	1370 / 622	\$23,150.00	\$ 41,044.00	
AEP - 80 C	80 gpm	200	1021	10 / 420	Belt	AC230/460V 3-Ph	1370 / 622	\$23,150.00	\$ 41,044.00	
AEP - 108 C	108 gpm	240	1021	15 / 520	Belt	AC230/460V 3-Ph	1530 / 694	\$24,299.00	\$ 41,972.00	
AEP - 132 C	115 gpm	300	1521	15 / 420	Belt	AC230/460V 3-Ph	1600 / 726	\$33,433.00	\$ 59,614.00	

(1) Maximum System Size is based on manufacturer-recommended over-sizing factor of 2.0 to 2.5.

Weights are approximate; specifications are subject to change without notice. Call factory or distributor for price quotation and actual lead times.

<b>Motor Starter Packages for 3-Phase Pumps (fits both Blackmer and Corken Pumps)</b>					
Description	Voltage	3 HP	5 HP	7.5 HP	10HP
Starter Package, Non-Explosion-Proof, NEMA 1 Indoor Enclosure; Start/Stop Station; Pilot Light; supplied loose for field installation.	AC 230 V	\$1,109.00	\$1,153.00	\$1,153.00	\$1,153.00
	AC 460 V	\$1,153.00	\$1,153.00	\$1,153.00	\$1,153.00
Starter Package, Non-Explosion-Proof, NEMA 3R Outdoor Enclosure; Start/Stop Station; Pilot Light; supplied loose for field installation.	AC 230 V	\$1,395.00	\$1,468.00	\$1,468.00	\$1,468.00
	AC 460 V	\$1,468.00	\$1,468.00	\$1,468.00	\$1,468.00
Installation of Non-Explosion-Proof Motor Starter on the Inside or the Outside of a Vaporizer Control Room.		AEP-INS-1 \$929.00 (per Starter Package)			
Starter Package, Explosion-Proof, NEMA 7,9,3R Outdoor Enclosure; Start/Stop Station; Pilot Light; supplied loose for field installation.	AC 230 V	\$3,261.00	\$3,349.00	\$3,349.00	\$3,349.00
	AC 460 V	\$3,349.00	\$3,349.00	\$3,349.00	\$3,349.00
Installation of Explosion-Proof Motor Starter on Pump Package (includes mounting frame and explosion-proof Flex-Conduit)		AEP-INS-2 \$2,047.00 (per Starter Package)			
Integration of pump control in vaporizer or vaporizer/blender control system; includes remote start/stop station in ex-proof enclosure, installed at pump skid.		\$ 2,664.00			
Automatic pump start/stop in response to pressure in storage tank(s); includes option "integration of pump control in vaporizer or vaporizer/blender control system"; includes Rosemount pressure transmitter in pump inlet.		\$ 5,578.00			

All Starter Packages consist of the motor starter (appropriately sized for the selected pump motor), integrated Start/Stop station, heater strips, and an enclosure. "Standard" configurations are available for indoor or outdoor installation in non-hazardous areas (such as the vaporizer control room); "Ex-Proof" configurations are designed for installation at the pump location. Factory installation of ex-proof starter packages includes a mounting frame attached to the pump skid, and ex-proof flexible conduit between the enclosure and the pump. Dual Pump Packages require 2 Starter Packages.

## Terms and Conditions, Warranty Information

The following are the standard terms and conditions of Alternate Energy Systems, Inc. for **domestic** customers. Actual terms and conditions for a specific order may have adjusted language and may be attached to the acknowledgement of the purchase order. Contact Alternate Energy Systems, Inc. for terms and conditions for export orders.

### Acceptance:

Where these terms and conditions are incorporated in a proposal submitted by Alternate Energy Systems, Inc. ("Seller"), that proposal, together with these terms and conditions, expresses the Seller's entire undertaking and responsibility when the Purchaser's written order is transmitted to the Seller within thirty (30) days from the proposal date, and when the Purchaser's order is accepted by the Seller at its offices. Any previous quotations, agreements, conversations, or understandings, are superseded hereby.

For all other orders, these terms and conditions shall govern the contract between the Purchaser and the Seller. Any deviation from these terms and conditions must be agreed upon by the Seller, in writing. Specifically, the fact that Seller provides product in response to an order issued by the Purchaser, carrying deviating terms and conditions, does not automatically indicate that the Seller has accepted the Purchaser's terms and conditions.

### Limited Warranty:

Seller guarantees that all products of its manufacture, sold pursuant hereto, shall be free of defects in workmanship and material, normal wear and tear excepted, for the standard period of one year from date of shipment from Seller. Certain products may carry shorter or longer warranty periods, in effect for these particular products at the time of shipment from the Seller. Commercial items, and other components, such as controls, electric motors, drives, etc., utilized in these manufactured products, are not guaranteed by Seller. Instead, they are covered by, and are subject to, their respective manufacturers' guarantees only. Complete products represented by, distributed by, or purchased and resold in any other manner by, Seller, are not guaranteed by Seller, but will be subject to their respective manufacturer's guarantee.

In the event of defects developing within the Seller's applicable guarantee period under normal and proper use, the Seller will only be obligated to furnish, F. O. B. point of manufacture or the Seller's plant, at its option, without charge, parts required to replace materials found defective; or, at Seller's option, replacement of defective item. Seller or its suppliers shall not be held liable for any further costs or expense, or for indirect or consequential damages, including removal or reinstallation cost, and lost profits. Deterioration or wear caused by chemicals, abrasive action, or excessive heat shall not constitute defects under warranty, unless such conditions are expressly provided for by the Seller, in writing. Products or parts that have been subject to accidental damage, misuse, unauthorized disassembly or alterations, improper installation, lack of proper lubrication, or lack of other service requirements established by the manufacturer, will not be covered by warranty. THE WARRANTY STATED HEREIN IS IN LIEU OF ALL OTHER WARRANTIES, EXPRESS, STATUTORY, OR IMPLIED; INCLUDING, WITHOUT LIMITATION, THAT OF MERCHANTABILITY AND FITNESS FOR A PARTICULAR PURPOSE.

### Taxes:

Unless otherwise specifically noted in a proposal, prices quoted by seller do not include any applicable city, county, state or federal taxes. Any of these taxes to which a transaction is subject, are to be borne by the Purchaser, even if collection is required by the Seller.

### Applicable Codes:

Seller or any manufacturer it represents, shall not be liable for any expense involved in meeting any federal, state or local codes. Federal codes, such as those represented in OSHA, refer to the employer (Purchaser) and not to the supplier (Seller). They cannot be delegated. However, the Seller will endeavor to help the Purchaser comply with these codes.

### Component Equipment:

Seller's sales proposals are based on supplying its chosen make of motors, controls, drives and miscellaneous incidental equipment of the type required. If the Purchaser specifies a particular brand of one of these devices, the Seller reserves the right to charge any additional price involved, and its estimated shipping date is subject to such delays as may be required to obtain any non-stock item.

### Shipping:

Seller will use all reasonable care in shipping the equipment and will endeavor to make shipment within the time estimated. However, it assumes no responsibility for loss of, or damage to, the equipment after shipment from its plant, or for unavoidable delays, such as those caused by fire, strikes, carriers, or other causes beyond the Seller's control. Unless instructed otherwise, all shipments will be insured at the buyer's expense and at the net invoice value of the goods.

### Erection and Installation:

Seller assumes no responsibility for improper operation of equipment due to faulty erection or installation, when the equipment is erected by the Purchaser or his designates.

### Cancellation:

All orders placed with, and accepted by, Seller are firm and not subject to cancellation, except by mutual consent. They are cancelable then only on terms that will indemnify the Seller against any losses incurred.

### Claims:

Claims for shortages or damage to merchandise should be made to the transportation company making delivery. Should any piece of equipment prove defective, it will be repaired or replaced under the applicable warranty provided herein. Under no circumstances should any items be returned to Seller or the manufacturer from which Seller procured the item, without prior written Return Goods Authorization from Seller.

If Goods are returned without obtaining Return Goods Authorization, Seller and its associated manufacturers will not be responsible for the cost of repairs made in the field, if they are made without the written agreement of, and specific written instructions from, Seller and the affected manufacturer, if any.

### Payment Terms:

Full net payment must reach Seller's office by the 30th day after invoice date. The following finance charges will apply for later payment, unless other agreements exist for that sale only:

The account is subject to a finance charge for late payment of the lower of (A) the maximum allowable rate, or (B) 1½ % per month (Annual Percentage Rate: 18%) on the total past due balance at any time that the past due balance includes any charge remaining unpaid 30 days after the date on which it was billed. There shall be no finance charge under a "Consumer Credit Transaction" as defined under the Federal Truth in Lending Law.

### Governing Law:

This agreement has been executed in, and shall be governed by, the laws of the State of Georgia.

### Security Agreement and Security Interest:

Purchaser agrees that Seller shall have and retain a security interest in the material furnished pursuant under this Agreement and, if full payment of all sums due is not received by Seller in accordance with the payment terms set forth herein and on the face hereof, Seller shall have the right to enter Purchaser's premises, and any other place where the material may be located, and repossess the material. This right of repossession shall be in addition to, and in no way in limitation of, any rights or remedies Seller may have under law or this Agreement by reason of Purchaser's failure to pay.

### Purchaser's Acceptance of above Conditions:

All orders shall be subject to the terms and conditions described above, and to no others, whatsoever. When attached to the Seller's written quotation, this document contains the entire agreement between the parties, and there will be no oral or written understandings, terms or conditions, and Purchaser will not have relied upon any conditions or representation not contained therein. No waiver, alteration or modification of the terms and conditions on this and the other side hereof shall be binding unless in writing and signed by an executive officer or by a duly authorized representative of the Seller.

THE PURCHASER'S RECEIPT OF THE INVOICE SHALL CONSTITUTE AN ACCEPTANCE BY THE PURCHASER OF ALL THE TERMS AND CONDITIONS CONTAINED DESCRIBED ABOVE, AND ANY ATTACHMENT HEREOF OTHER THAN ANY TERMS OR CONDITIONS TO WHICH THE PURCHASER SHALL PROMPTLY TAKE EXCEPTION BY SPECIFIED WRITTEN OBJECTION.

Version 12/99 (05/04)