



Alternate Energy Systems, Inc.

A Corporation devoted to Energy-Oriented Needs

LPG-Vapor / Air Mixing Systems

Venturi - Type

- **Capacities from 7MM/h to over 200 MM BTU/h**
- **Complete with Steel Skid, Controls and Surge Tank**
- **Dual Solenoid Valves for each Venturi (“Static” & “Dynamic”)**
- **For Standby Systems or Peak Shaving Applications**
- **For Combination with Existing Vaporizers**
- **Replacement for existing, less reliable mixers**
- **Standard Controls for smaller systems (up to 20 MM BTU)**
- **PLC Controls for larger systems**
- **Also available as packaged system with vaporizer**

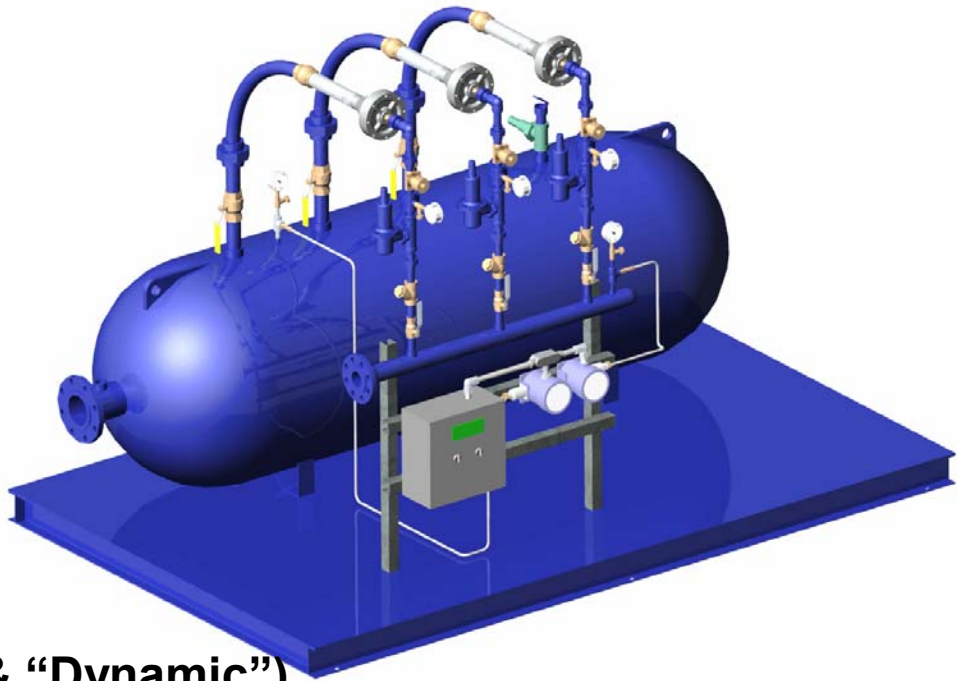

What are LPG-Vapor / Air Mixers ?

LPG vapor is not directly compatible with natural gas and must be mixed with air before it can be used in equipment and appliances that are set up for natural gas. LPG vapor/air mixer systems mix vapor from a vapor source (such as a vaporizer) with air at a pre-set ratio, producing a gas, often called Synthetic Natural Gas (SNG) that is directly compatible with natural gas. This allows users to switch back and forth between natural gas supplied by their utility company and their own, LPG based backup or peak shaving system, without having to change the setup of their burners, boilers, etc.

The most common vapor/air mixers are based on venturi tube mixing devices. AES uses the high pressure/high efficiency Hallberg Venturi Systems (HVS), generating gas pressures of up to 10 psi without the need of compressed air supply, making these systems very economical to operate. For very large capacity and/or high pressure applications, we use our patented Piston Operated Mixing Systems, POM-30 to POM-60 (see separate brochure).

How do Alternate Energy Systems' HVS LPG-Vapor / Air Mixers work ?

HVS Systems are designed to be used with an existing LPG vapor source, such as a vaporizer, or as the replacement for less efficient or less reliable LPG-vapor/air mixing systems. They come complete with steel skid, vapor inlet header, venturi arrangements, surge tank, electric/electronic controls, and all other equipment necessary for safe operation.

LPG vapor from an appropriate source, i.e. a vaporizer, enters the vapor inlet header and then passes through a pressure regulator. From there, the pressure-adjusted vapor flows through the high precision nozzle and the venturi tube section of the HVS into the surge tank. While the vapor passes through the tube section, the venturi effect "siphons" ambient air through the air-intake/check-valve combination and sends it into the surge tank together with the LPG vapor.

The amount of air mixed into the LPG vapor stream is largely depending on shape and dimension of the nozzle/venturi tube configuration, as well as on the LPG vapor pressure. The properties of the mixed gas (calorific value) can be adjusted by changing the vapor pressure at the regulator. Typically, adjusting the vapor/air mixture to a specific gravity of 1.3 assures direct compatibility of the mixed gas with natural gas. Most important for the interchangeability and compatibility of LPG/air mixtures with natural gas is the Wobbe Index Number, which is defined as the Gross Heat Value divided by the Square Root of the Specific Gravity. Gasses with the same Wobbe number are assumed to be directly interchangeable. The Wobbe indices for natural gas (1050 BTU/cuft; S.G. = 0.6) and Propane/Air mixture (1450 BTU/cuft; S.G. = 1.3) are sufficiently close to each other, allowing changeovers from one gas to the other without any changes to the setup of the connected loads.

$$\text{Wobbe Index} = \frac{\text{Gross Heat Value}}{\sqrt{\text{Specific Gravity}}}$$

All HVS systems monitor the gas pressure in the surge tank. Increased demand on the system results in a momentary drop in tank pressure. In systems with three or more venturi arrangements,

this drop is detected by a pressure transmitter which is connected to a PLC. (In smaller systems, these functions are provided by mechanical pressure switches.) The PLC then activates (opens) the "dynamic" solenoid valve in the first venturi arrangement, which begins producing mixed gas. As the load increases, and tank pressure decreases further, additional venturi arrangements are activated, producing additional gas. Through the use of electronic pressure transmitters rather than mechanical pressure switches, the setpoints between tank pressures can be kept very close together, resulting in very little pressure fluctuations between no-load, partial-load and full-load conditions, in large systems.

The PLC in systems with three or more venturi arrangements not only "sequences" the venturi lines, but also controls all other system functions. The PLC also communicates with a display unit, indicating system pressures and any trouble conditions that may occur. The PLC may also be used to "interlock" the HVS system with an external vaporizer.

Size and configuration of the PLC, Display Unit, Pressure Transmitters, and other system components, varies with the size of the mixer and can easily be modified to meet almost any specific needs.

All HVS Mixers are equipped with two solenoid valves per venturi train. The "dynamic" solenoid valve opens and closes each time a venturi train is activated to produce mixed gas. The "static" solenoid valve opens when the mixer is started and stays open until the mixer is stopped, or until a high-pressure alarm occurs. This feature provides an additional level of safety and prevents the unwanted discharge of mixed gas in case of a failure of the "dynamic" solenoid valve.

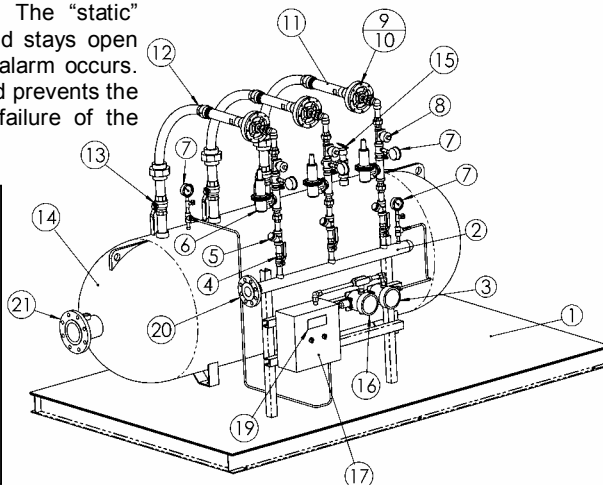
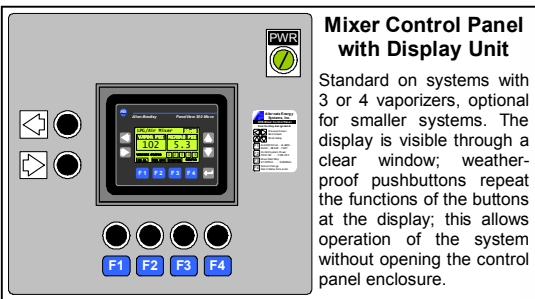

- 1 Steel Skid
- 2 Vapor Header
- 3 Low Vapor Pressure Sw.
- 4 Ball Valve
- 5 "Y" Type Strainer
- 6 Pressure Regulator
- 7 Pressure Gauge
- 8 "Static" Solenoid Valve
- 9 Air Intake / Check Valve
- 10 Venturi Nozzle
- 11 Venturi Tube
- 12 Check Valve
- 13 Ball Valve
- 14 Surge (Receiver) Tank
- 15 Relief Valve
- 16 Pressure Transmitter
- 17 Control Panel
- 18 PLC (not shown)
- 19 Display Unit
- 20 Vapor Inlet
- 21 Mixed Gas Outlet

Features and Specifications

Model Number	Nominal Capacity ¹ 5 to 8 psi (9 to 12 psi version) in MMBTU/h	Number of Venturis ² 5 to 8 psi (9 to 12 psi version)	Surge Tank Capacity US-gal (liter)	Vapor Inlet Connection	Mixed Gas Surge Tank Connection	Approximate Skid Size in Inches (mm) W x L x H	Approximate Shipping Weight lbs (kg)
HVS - 7 MM	7 (7)	1 (1)	120 (450)	3/4" FNPT	2" FNPT	W = 54 (1372) L = 54 (1372) H = 83 (2108)	800 (363)
HVS - 10 MM	10 (10)	1 (1)	120 (450)				800 (363)
HVS - 14 MM	14 (14)	2 (2)	120 (450)				850 (386)
HVS - 20 MM	20 (21)	2 (2)	120 (450)				850 (386)
HVS - 30 MM	30 (28)	3 (3)	250 (950)	2" - 300# Raised Face Flange	2" - 150# Raised Face Flange	W = 65 (1651) L = 102 (2591) H = 70 (1778)	1000 (454)
HVS - 40 MM	40 (42)	4 (4)	250 (950)				1050 (477)
HVS - 50 MM	50 (49)	5 (4)	250 (950)				1100 (499)
HVS - 60 MM	60 (63)	6 (5)	500 (1893)				1700 (772)
HVS - 70 MM	70 (70)	7 (6)	500 (1893)	2" - 300# Raised Face Flange	3" - 150# Raised Face Flange	W = 65 (1651) L = 128 (3251) H = 80 (2032)	1750 (795)
HVS - 80 MM	80 (77)	8 (6)	500 (1893)				1800 (817)
HVS - 90 MM	90 (91)	9 (7)	1000 (3785)				2700 (1226)
HVS - 100 MM	100 (105)	10 (8)	1000 (3785)				2750 (1249)
HVS - 110 MM	110 (112)	11 (9)	1000 (3785)				2800 (1271)
HVS - 120 MM	120 (119)	12 (9)	2000 (7570)				Component layout and skid sizes for systems with nominal capacities of 120 MMBTU/h or larger are custom-designed to fit the locally available space. Please contact AES to discuss your specific situation and for weights and dimensions.
HVS - 130 MM	130 (133)	13 (10)	2000 (7570)				
HVS - 140 MM	140 (140)	14 (11)	2000 (7570)				
HVS - 150 MM	150 (154)	15 (12)	2000 (7570)				

¹Nominal Capacity for Propane/Butane @ 0°F Liquid Inlet Temperature.

²Actual number of venturi arrangements may vary with desired mixed gas pressure.

All weights and dimensions are approximate. All Specifications are subject to change without notice.

	HVS-7MM	HVS-10MM	HVS-14MM	HVS-20MM	HVS-30MM	HVS-40MM	HVS-50MM	HVS-60MM	HVS-70MM	HVS-80MM	HVS-90MM	HVS-100MM	HVS-110MM	HVS-120MM	HVS-130MM	HVS-140MM	HVS-150MM
Electrical Requirements	AC 110 V 60 Hz, single phase, 15 A or less (Export: AC 220 V 50 Hz, 15 A or less)																
Low Vapor Pressure Switch	S	S	S	S	-	-	-	-	-	-	-	-	-	-	-	-	-
Tank Pressure Monitor, Pressure Switch 1	S	S	S	S	-	-	-	-	-	-	-	-	-	-	-	-	-
Tank Pressure Monitor, Pressure Switch 2	-	-	S	S	-	-	-	-	-	-	-	-	-	-	-	-	-
High Mixed Gas Pressure Switch	S	S	S	S	-	-	-	-	-	-	-	-	-	-	-	-	-
Standard Electric System Controls	S	S	S	S	-	-	-	-	-	-	-	-	-	-	-	-	-
Rosemount Pressure Transmitter for Low/High Vapor Alarms	O	O	O	O	S	S	S	S	S	S	S	S	S	S	S	S	S
Tank Pressure Monitor, Rosemount Transmitter; for venturi control and Low/High MixGas Alarms	O	O	O	O	S	S	S	S	S	S	S	S	S	S	S	S	S
Allen-Bradley MicroLogix Programmable Logic Controller (PLC)	O	O	O	O	S	S	S	S	S	S	S	S	S	S	S	S	S
Operator Interface Allen-Bradley PanelView 300 Micro	O	O	O	O	S	S	S	S	S	S	S	S	S	S	S	S	S

S = Standard Equipment

O = Optional Equipment

All specifications are subject to change without notice.

Drawings

Model Numbers

- HVS - 30 MM
- HVS - 40 MM
- HVS - 50 MM
- HVS - 60 MM
- HVS - 70 MM
- HVS - 80 MM
- HVS - 90 MM
- HVS - 100 MM
- HVS - 110 MM

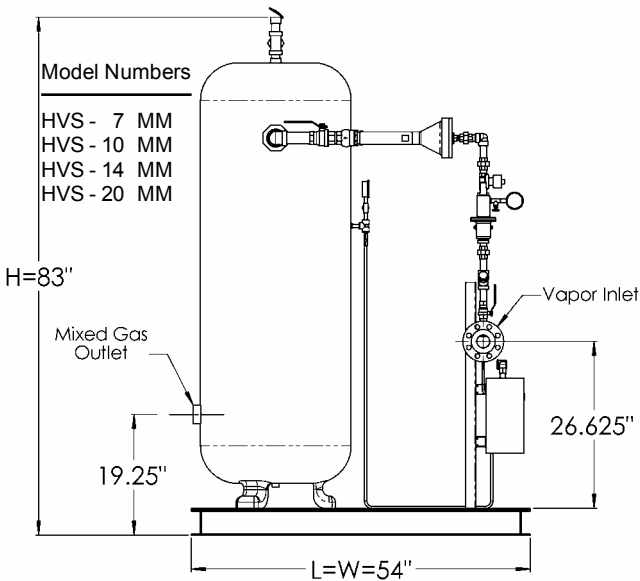
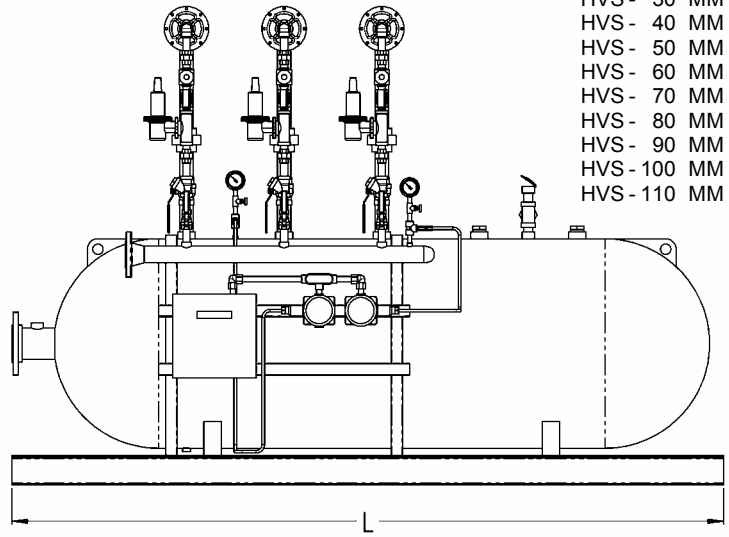
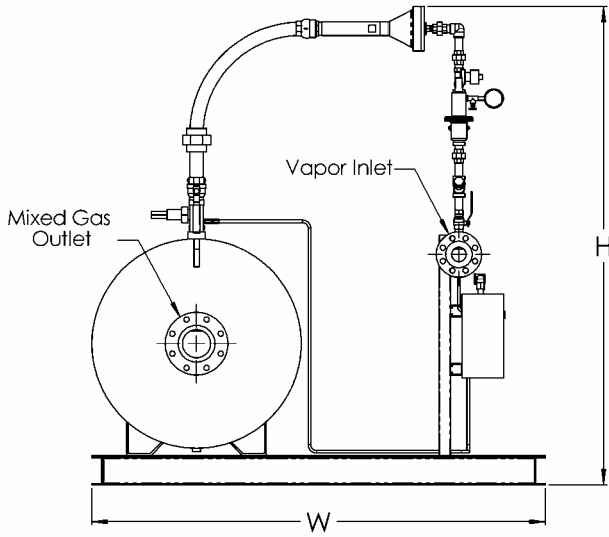

Dimensions	W	L	H
HVS - 7 MM			
HVS - 10 MM	54"	54"	83"
HVS - 14 MM	(1372 mm)	(1372 mm)	(2108 mm)
HVS - 20 MM			
HVS - 30 MM	65"	102"	70"
HVS - 40 MM	(1651 mm)	(2591 mm)	(1778 mm)
HVS - 50 MM			
HVS - 60 MM	65"	128"	80"
HVS - 70 MM	(1651 mm)	(3251 mm)	(2032 mm)
HVS - 80 MM			
HVS - 90 MM	65"	199"	84"
HVS - 100 MM	(1651 mm)	(5055 mm)	(2134 mm)
HVS - 110 MM			

Our Address

Alternate Energy Systems, Inc.
 210 Prospect Park P.O. Box 2469
 Peachtree City, GA 30269, USA

Phone 770-487-8596
 Fax 770-631-4306
 Toll Free 800-410-9161

E-Mail info@altenergy.com
 WebSite www.altenergy.com

Your AES Distributor