



**Alternate Energy Systems, Inc.**

**A Corporation devoted to Energy-Oriented Needs**

# **LPG-Vaporizer / Air Mixing Systems**

**Venturi - Type Mixing System with Direct Fired Vaporizer**

- **Capacities from 7MM BTU/h to 40 MM BTU/h**
- **Complete with Steel Skid, Vaporizer, Mixer, Controls and Surge Tank**
- **For Standby Systems or Peak Shaving Applications**
- **Electromechanical Controls for small systems (up to 20 MM BTU)**
- **PLC Controls for larger systems**

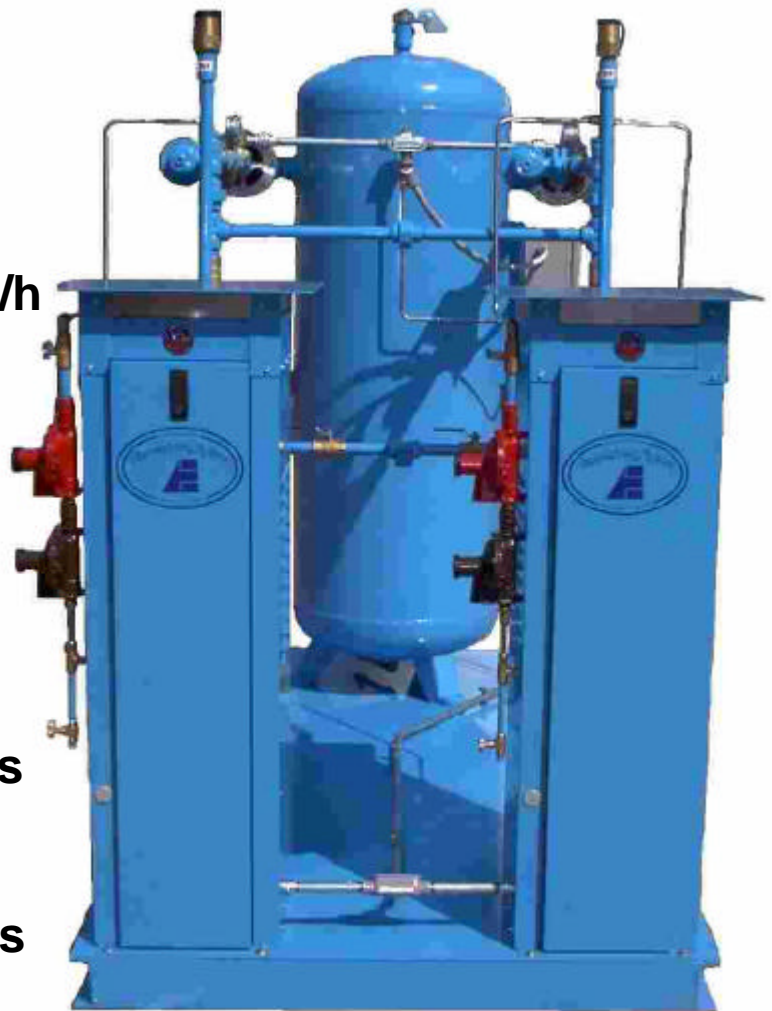

Model Number	Capacity	Model Number	Capacity
AE- 80 / HVS- 7	7 MM BTU/h	AE-240 / HVS-20	20 MM BTU/h
AE-120 / HVS-10	10 MM BTU/h	AE-360 / HVS-30	30 MM BTU/h
AE-160 / HVS-14	14 MM BTU/h	AE-480 / HVS-40	40 MM BTU/h

# What are Vaporizer/Mixer Systems ?

**L**PG vapor is not directly compatible with natural gas and must be mixed with air before it can be used in equipment and appliances that are set up for natural gas. LPG vaporizer/mixer systems consist of a vaporizer to convert liquid LPG into LPG vapor and a vapor/air mixer to mix the vapor with air at a pre-set ratio. They produce a gas mixture that is directly compatible with natural gas. This allows users to switch back and forth between natural gas supplied by their utility company and their own, LPG based backup or peak shaving system, without having to change the setup of their burners, boilers, etc.

The most cost-effective vaporizer/mixer systems are the ones described in this brochure. They use Direct Fired Vaporizers (AES model numbers AE-80 or AE-120) and a Hallberg Venturi Mixer (AES model numbers HVS-7 to HVS-40), generating gas pressures of up to 12 psi without the need of compressed air supply, making these systems very economical to operate. For larger capacities and/or high pressure applications, vaporizer/mixer systems based on Water Bath Vaporizers and Hallberg Venturi Mixers, or based on Water Bath Vaporizers and our patented Piston Operated Mixing Systems, POM-30 to POM-60, are used (see separate brochures for details).

## How do Alternate Energy Systems' Vaporizer/Mixer Systems with Direct Fired Vaporizer work ?

**V**aporizer/Mixer Systems are designed for easy installation and long, trouble-free service. They come complete with steel skid, vaporizer, venturi arrangements, surge tank, electric/electronic controls, and all other equipment necessary for safe operation. They are factory tested and ready to be placed on a concrete slab or other, non-combustible ground cover. After connection to liquid LPG, mixed gas line and electrical supply, they can be ready to produce "Synthetic Natural Gas" within a few hours after arrival of the system at the job site.

Liquid LPG from a storage tank is transferred to the vaporizer. Typically, a liquid LPG transfer pump is installed in the liquid supply line, keeping liquid pressure at approximately 100 psi (145 psi for systems with 12 psi sendout pressure). After vaporization of the LPG in the vaporizer, vapor enters the inlet header and then passes through a pressure regulator. From there, the pressure-adjusted vapor flows through the high precision nozzle and the venturi tube section of the HVS into the surge tank. While the vapor passes through the tube section, the venturi effect "siphons" ambient air through the air-intake/check-valve combination and sends it into the surge tank together with the LPG vapor.

The systems monitor the gas pressure in the surge tank. Increased demand on the system results in a momentary drop in tank pressure. If the tank pressure drops below certain setpoints, one or more additional venturi assemblies are activated. Systems with one or two venturi assemblies use electro-mechanical control components (pressure switches) to monitor the surge tank pressure. Systems with three or more venturi assemblies use electronic pressure transmitters and a programmable logic controller (PLC) to monitor and control all system functions. The PLC also communicates with a display unit, indicating system pressures, and any trouble conditions that may occur. The PLC also performs the function of a first-outage annunciator panel (with date/time stamp).

Size and configuration of the PLC, Display Unit, Pressure Transmitter, and other system components is variable and depend largely on customer preferences. The specifications given in the table on the next page represent standard configurations. Please contact your authorized AES distributor/installer for modifications to meet your specific needs.

For more detailed information and specifications about direct fired vaporizers and HVS mixing systems, please refer to the following brochures: "Direct Fired LPG Vaporizers" and "LPG-Vapor / Air Mixing Systems, Venturi - Type".

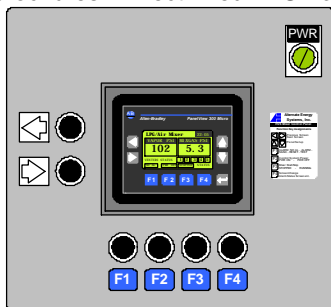

**Mixer Control Panel with Display Unit**

(Standard on systems with 3 or 4 vaporizers, optional for smaller systems. The display is visible through a clear window; weather-proof pushbuttons repeat the functions of the buttons at the display; this allows operation of the system without opening the control panel enclosure.)

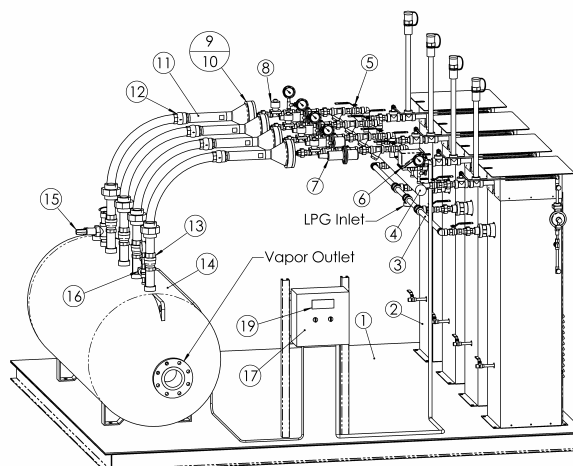

- 1 Steel Skid
- 2 Vaporizer
- 3 Liquid Inlet Header
- 4 Vapor Header
- 5 Ball Valve
- 6 Low Vapor Pressure Sw.
- 7 Pressure Regulator
- 8 Solenoid Valve
- 9 Air Intake / Check Valve
- 10 Venturi Nozzle
- 11 Venturi Tube
- 12 Check Valve
- 13 Ball Valve
- 14 Surge Tank
- 15 Relief Valve
- 16 Pressure Transmitter
- 17 Control Panel
- 18 PLC
- 19 Display Unit

# Features and Specifications

## General Specifications

For detailed specifications on Direct Fired Vaporizers, please refer to brochure "Direct Fired LPG Vaporizers".  
For detailed specifications on Venturi-Type Mixing Systems, please refer to brochure "LPG-Vapor/Air Mixing Systems".

Model Number	Nominal Capacity in MMBTU (Kcal)	Number of Venturis at 5 psi (0.35 bar)	Number and Model of Vaporizers	Surge Tank Capacity US-gal (Liter)	Liquid Inlet Connection	Mixed Gas Surge Tank Connection	Electrical Requirements	Approximate Skid Size in Inches W x L x H	Approximate Shipping Weight in lbs (Kg)
AE- 80 / HVS - 7 MM	7 (1764)	1	1 AE - 80	120 (450)	3/4" FNPT	2" FNPT	AC 110 V 60 Hz Single Phase 15 A Circuit	48x106x71¼	1130 (515)
AE-120 / HVS-10 MM	10 (2520)	1	1 AE - 120	120 (450)	3/4" FNPT	2" FNPT		48x106x80¼	1200 (545)
AE-160 / HVS-14 MM	14 (3528)	2	2 AE - 80	120 (450)	3/4" FNPT	2" FNPT		48x106x71¼	1460 (665)
AE-240 / HVS-20 MM	20 (5040)	2	2 AE - 120	120 (450)	3/4" FNPT	2" FNPT		48x106x80¼	1600 (730)
AE-360 / HVS-30 MM	30 (7560)	3	3 AE - 120	250 (950)	3/4" FNPT	150 # Raised Face Flange (Customer to specify Size).		100x110x80¼	2000 (910)
AE-480 / HVS-40 MM	40 (10080)	4	4 AE - 120	250 (950)	3/4" FNPT			100x110x80¼	2300 (1045)

Nominal Capacity for Propane/Butane @ 0°F Liquid Inlet Temperature. Dimensions and weights are approximate. Specifications subject to change without notice.

## Control Component Specifications

	AE - 80 / HVS - 7MM	AE - 120 / HVS - 10MM	AE - 160 / HVS - 14MM	AE - 240 / HVS - 20MM	AE - 360 / HVS - 30MM	AE - 480 / HVS - 40MM
Low Vapor Pressure Switch Mechanical Pressure Switch, UE-440 or similar, or Electronic Pressure Switch, WIKA PS-10 or similar	Standard	Standard	Standard	Standard	-	-
Vapor Pressure Transmitter Rosemount 2088 or similar	Option	Option	Option	Option	Standard	Standard
Tank Pressure Monitor, Pressure Switch 1 Mechanical Pressure Switch, UE-440 or similar	Standard	Standard	Standard	Standard	-	-
Tank Pressure Monitor, Pressure Switch 2 Mechanical Pressure Switch, UE-440 or similar	-	-	Standard	Standard	-	-
High Mixed Gas Pressure Switch Mechanical Pressure Switch, UE-440 or similar	Standard	Standard	Standard	Standard	-	-
Tank Pressure Monitor Pressure Transmitter Rosemount 2088 or similar	Option	Option	Option	Option	Standard	Standard
Standard Electric System Controls Direct-Contact-Interlock with Single Control System Relay	Standard	Standard	Standard	Standard	-	-
Programmable Logic Controller (PLC) Allen-Bradley MicroLogix-1000Analog	Option	Option	Option	Option	Standard	Standard
3-inch Graphic Display with weather-proof external pushbuttons (Allen-Bradley PanelView-300Micro)	Option	Option	Option	Option	Standard	Standard

System Control Configuration shown are "typical". Customized system control configurations are available. Please contact factory with your specific requirements.

## High Pressure Option

Standard Venturi type mixers use ambient air to mix with LPG vapor. The maximum achievable system pressure largely depends on shape and dimension of the nozzle/venturi tube configuration, as well as on the LPG vapor pressure. Keeping the LPG vapor at reasonable pressures, mixed gas pressures of up to 8 to 9 psi can be generated safely and reliably. If higher mixed gas pressures are required, compressed air supply is required.

High Pressure Options are available for all our venturi mixer systems. They consist of a separate pressure regulator and associated controls for each venturi assembly. Using this option, system pressures of up to 50 psi can be generated.

The table on the right shows the air requirements for various system sizes. The numbers are based on propane as the LPG feedstock and include a 15% safety margin for specific gravities of 1.28 to 1.30, allowing the mixed gas to be a direct replacement for typical natural gas with a calorific value of 1000 BTU/cuft and a specific gravity of 0.6.

Approximate Compressed Air Requirements	
Model Number	Air Supply
AE- 80 / HVS - 7 MM	51 scfm @ 100 psi
AE-120 / HVS-10 MM	75 scfm @ 100 psi
AE-160 / HVS-14 MM	103 scfm @ 100 psi
AE-240 / HVS-20 MM	148 scfm @ 100 psi
AE-360 / HVS-30 MM	222 scfm @ 100 psi
AE-480 / HVS-40 MM	295 scfm @ 100 psi

# Drawings

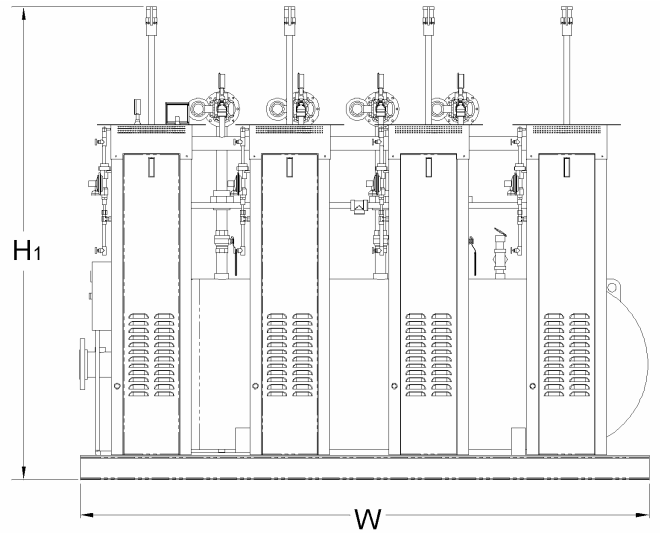
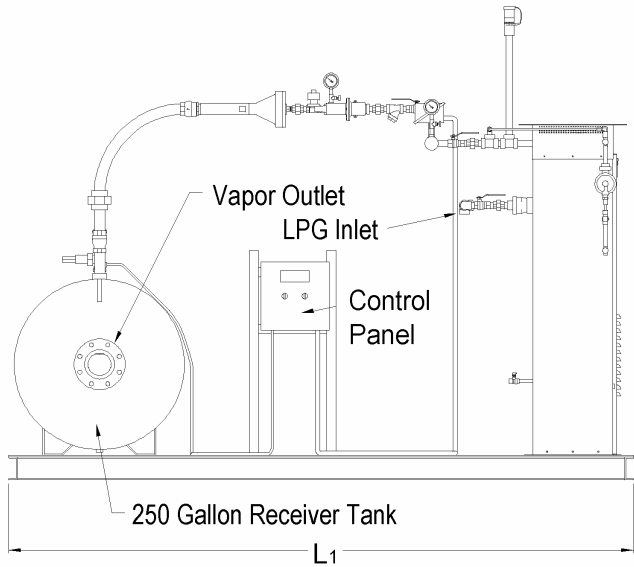

AE-360/HVS-30  
AE-480/HVS-40

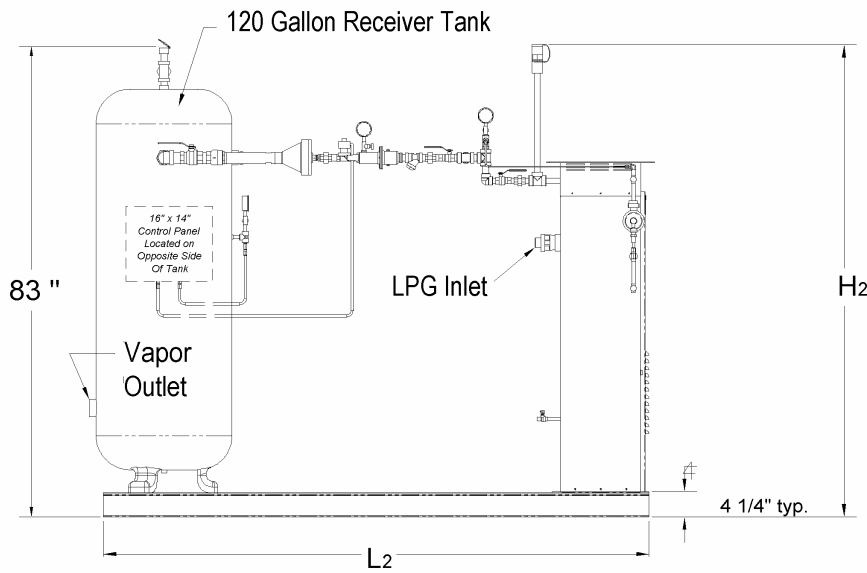

AE- 80/HVS- 7  
AE-120/HVS-10  
AE-160/HVS-14  
AE-240/HVS-20

Dimensions in inches	W	L <sub>1,2</sub>	H <sub>1,2</sub>
AE- 80/HVS- 7MM	48	106	71¼
AE-120/HVS-10MM	48	106	80¼
AE-160/HVS-14MM	48	106	71¼
AE-240/HVS-20MM	48	106	80¼
AE-360/HVS-30MM	100	110	80¼
AE-480/HVS-40MM	100	110	80¼

System configurations shown are "typical" and are subject to change without notice. Dimensions are approximate and are subject to change without notice.

## Our Address

Alternate Energy Systems, Inc.  
210 Prospect Park P.O. Box 2469  
Peachtree City, GA 30269, USA

Phone 770-487-8596  
Fax 770-631-4306  
Toll Free 800-410-9161

E-Mail [info@altenergy.com](mailto:info@altenergy.com)  
WebSite [www.altenergy.com](http://www.altenergy.com)

## Your AES Distributor